

ROBOTICS

Product manual

OmniCore E10



Trace back information:
Workspace 24A version a18
Checked in 2024-03-14
Skribenta version 5.5.019

Product manual

OmniCore E10

OmniCore

Document ID: 3HAC079399-001

Revision: L

The information in this manual is subject to change without notice and should not be construed as a commitment by ABB. ABB assumes no responsibility for any errors that may appear in this manual.

Except as may be expressly stated anywhere in this manual, nothing herein shall be construed as any kind of guarantee or warranty by ABB for losses, damage to persons or property, fitness for a specific purpose or the like.

In no event shall ABB be liable for incidental or consequential damages arising from use of this manual and products described herein.

This manual and parts thereof must not be reproduced or copied without ABB's written permission.

Keep for future reference.

Additional copies of this manual may be obtained from ABB.

Original instructions.

© Copyright 2019-2024 ABB. All rights reserved.
Specifications subject to change without notice.

Table of contents

Overview of this manual	9
Product documentation	12
1 Safety	15
1.1 Safety information	15
1.1.1 Limitation of liability	15
1.1.2 Safety data	16
1.1.3 Requirements on personnel	17
1.2 Safety signals and symbols	18
1.2.1 Safety signals in the manual	18
1.2.2 Safety symbols on controller labels	20
1.3 Robot stopping functions	22
1.3.1 Protective stop and emergency stop	22
1.3.2 About emergency stop	24
1.3.3 Enabling device and hold-to-run functionality	25
1.4 Robot operating modes	26
1.4.1 About the manual mode	26
1.4.2 About the automatic mode	28
1.5 Safety during installation and commissioning	29
1.6 Safety during operation	32
1.7 Safety during maintenance and repair	33
1.8 Safety during troubleshooting	34
1.9 Safety during decommissioning	35
2 Controller description	37
2.1 OmniCore E10	37
2.2 Technical data for OmniCore E10 controller	38
2.3 Safety functions and safety related data for OmniCore E10	42
2.4 The unit is sensitive to ESD	43
2.5 Handling of FlexPendant	44
2.6 Network security	45
2.7 Open source and 3rd party components	46
2.8 ABB Connected Services (ABB Ability)	47
3 Installation and commissioning	49
3.1 Introduction to installation and commissioning	49
3.2 Installation activities	50
3.3 Transporting and handling	51
3.3.1 Unpacking	51
3.3.2 Storing	52
3.4 On-site installation	53
3.4.1 Required installation space	53
3.4.2 Mounting the controller with 19" rack mounting kit	55
3.4.3 Mounting the controller with design front mounting kit [3001-3]	57
3.4.4 Mounting the FlexPendant holder	60
3.4.5 Changing the fan control functionality	66
3.5 Electrical connections	67
3.5.1 Connectors on the OmniCore E10 controller	67
3.5.2 Connecting cables to the controller	70
3.5.3 Connecting the manipulator to the controller	77
3.5.4 Fitting the connector for incoming mains	78
3.5.5 Connecting incoming mains and protective earth to the controller	79
3.5.6 Detaching and attaching a FlexPendant	81
3.5.7 Ethernet networks on OmniCore	85
3.5.8 Descriptions for connectors	87
3.5.9 Configuring robot stopping functions	98

Table of contents

3.5.10	Programmable stop functions	101
3.6	I/O system	104
3.6.1	Available industrial networks	104
3.6.2	Scalable I/O, external	105
3.7	Installing add-on devices	106
3.7.1	Installing Integrated Vision	106
3.7.2	Installing the scalable I/O devices	108
3.8	Initial test before commissioning	110
4	Maintenance	111
4.1	Maintenance schedule for the OmniCore controller	111
4.2	Inspection activities	112
4.2.1	Inspection of controller	112
4.3	Cleaning activities	113
4.3.1	Cleaning of the controller cabinet	113
4.3.2	Cleaning the FlexPendant	114
4.4	Function tests	116
4.4.1	Function test of emergency stop	116
4.4.2	Function test of manual, auto, and manual full speed mode with FlexPendant	117
4.4.3	Function test of three-position enabling device	118
4.4.4	Function test of safety switches	119
4.4.5	Function test of Automatic Stop	120
4.4.6	Function test of General Stop	121
4.4.7	Function test of external emergency stop	122
4.4.8	Function test of ESTOP_STATUS output	123
4.4.9	Function test of reduced speed control	124
5	Repair	125
5.1	Introduction to repair	125
5.2	Replacing parts inside the controller	126
5.2.1	Opening the robot controller	126
5.2.2	Replacing the fans	128
5.2.2.1	Replacing the small fans	130
5.2.3	Replacing the power unit	134
5.2.4	Replacing the drive unit	141
5.2.5	Replacing the computer and logic unit	147
5.3	Replacing parts on the front panel	154
5.3.1	Replacing the manipulator signal (SMB) and motors power unit harness assembly	154
5.3.2	Replacing the incoming mains connector	160
5.4	Replacing parts on the FlexPendant	164
5.4.1	Replacing the power cable and power cable cover	164
5.4.2	Replacing the joystick protection	169
5.4.3	Replacing the fasten strip	172
6	Troubleshooting	173
6.1	Introduction to troubleshooting	173
6.2	Troubleshooting fault symptoms	175
6.2.1	No LEDs are lit on the controller	176
6.2.2	Start-up failure	179
6.2.3	System update failure	180
6.2.4	Problem releasing the robot brakes	181
6.2.5	Problem starting or connecting the FlexPendant	184
6.2.6	Problem using the joystick	188
6.2.7	Controller fails to start	189
6.2.8	Reflashing firmware failure	190
6.2.9	Inconsistent path accuracy	191
6.2.10	Controller is overheated	193

6.3	Troubleshooting units	194
6.3.1	Troubleshooting LEDs in the controller	194
6.3.2	Troubleshooting the FlexPendant	195
6.3.3	Troubleshooting the drive unit	196
6.3.4	Troubleshooting the power unit	199
6.3.5	Troubleshooting fieldbuses and I/O	201
6.3.6	Troubleshooting the computer and logic unit	202
7	Decommissioning	205
7.1	Introduction to decommissioning	205
7.2	Environmental information	206
8	Reference information	209
8.1	Introduction	209
8.2	Applicable standards	210
8.3	Unit conversion	211
8.4	Standard toolkit for controller	212
8.5	Screw joints	213
8.6	Weight specifications	214
8.7	Lifting accessories and lifting instructions	215
9	Spare parts	217
9.1	Controller parts	218
9.1.1	Controller system parts	219
9.1.2	Mains connection parts	222
9.1.3	Logic parts	223
9.1.4	Application parts	224
9.1.5	Cabinet parts	225
9.1.6	Miscellaneous parts	228
9.1.7	Cables	230
9.2	FlexPendant parts	231
9.3	Manipulator cables	232
9.3.1	Manipulator cables	232
9.3.2	Customer cables - CP/CS connectors (option)	233
9.3.3	Customer cables - Ethernet floor cables	234
Index		235

This page is intentionally left blank

Overview of this manual

About this manual

This manual contains instructions for:

- mechanical and electrical installation of the controller
- maintenance of the controller
- mechanical and electrical repair of the controller

Usage

This manual should be used during:

- installation and commissioning, from lifting the product to its work site and securing it to the foundation, to making it ready for operation
- maintenance work
- repair work
- decommissioning work



Note

It is the responsibility of the integrator to conduct a risk assessment of the final application.

It is the responsibility of the integrator to provide safety and user guides for the robot system.

Who should read this manual?

This manual is intended for:

- installation personnel
- maintenance personnel
- repair personnel.

Prerequisites

A maintenance/repair/installation craftsman working with an ABB robot must:

- be trained by ABB and have the required knowledge of mechanical and electrical installation/repair/maintenance work.
- be trained to respond to emergencies or abnormal situations.

Product manual scope

The manual covers all variants and designs of the OmniCore E10. Some variants and designs may have been removed from the business offer and are no longer available for purchase.

Continues on next page

References



Tip

All documents can be found via myABB Business Portal, www.abb.com/myABB.

Document name	Document ID
<i>Product specification - OmniCore E line</i>	3HAC079823-001
<i>Circuit diagram - OmniCore E10</i>	3HAC076810-008
<i>Operating manual - RobotStudio</i>	3HAC032104-001
<i>Operating manual - OmniCore</i>	3HAC065036-001
<i>Operating manual - Integrator's guide OmniCore</i>	3HAC065037-001
<i>Application manual - Force control with software and hardware</i>	3HAC070206-001
<i>Technical reference manual - System parameters</i>	3HAC065041-001
<i>Application manual - Connected Services</i>	3HAC028879-001
<i>Safety manual for robot - Manipulator and IRC5 or OmniCore controller</i>	3HAC031045-001

Revisions

Revision	Description
A	First edition.
B	Published in release 21D. The following updates are made in this revision: <ul style="list-style-type: none"> Added supported robot IRB 1200, 910INV and 920. Updated structure in section Descriptions for connectors on page 87. Updated structure in section Controller parts on page 218. Updated the section Ethernet networks on OmniCore on page 85.
C	Published in release 22A. The following updates are made in this revision: <ul style="list-style-type: none"> Added information on decoupling ES output and ES input, see Descriptions for connectors on page 87, and Configuring robot stopping functions on page 98. Information about I/O Network added in section "Firewall settings". Updated safety data, see Safety functions and safety related data for OmniCore E10 on page 42
D	Published in release 22B. The following updates are made in this revision: <ul style="list-style-type: none"> Added note that the content of the section <i>ABB Ability</i> is only available in English (also in translated manuals). Updated manipulator cables in section Manipulator cables on page 232. Added desktop mounting kit installation procedure in section Mounting the controller with design front mounting kit [3001-3] on page 57. Supported EtherNet/IP Adapter is added. Supported UL/CSA is added. Supported scalable I/O external is added.
E	Published in release 22C. The following updates are made in this revision: <ul style="list-style-type: none"> Updated the section Controller fails to start on page 189. Updated the section Airborne noise level on page 40.

Continues on next page

Revision	Description
F	Published in release 22D. The following updates are made in this revision: <ul style="list-style-type: none"> Minor corrections in Connecting incoming mains and protective earth to the controller on page 79.
G	Published in release 23A. The following updates are made in this revision: <ul style="list-style-type: none"> Reserved 24V_EXT for next release in Descriptions for connectors on page 87. Minor corrections for the front design mounting kit. Changed the name from "Load Current" to "Line fusing" in section Technical data for OmniCore E10 controller on page 38.
H	Published in release 23B. The following updates are made in this revision: <ul style="list-style-type: none"> New spare parts added in Vision parts on page 228.
J	Published in release 23C. The following updates are made in this revision: <ul style="list-style-type: none"> Added supported robot IRB 1090. FCC statement updated in ABB Connected Services (ABB Ability) on page 47. Minor corrections.
K	Published in release 23D. The following updates are made in this revision: <ul style="list-style-type: none"> ABB Connect is the new name for ABB Ability Connected Services. Added supported robot IRB 930.
L	Published in release 24A. The following updates are made in this revision: <ul style="list-style-type: none"> Updated protection class of FlexPedant in section Protection classes on page 40. Updated spare part number of FlexPedant in section FlexPendant parts on page 231.

Product documentation

Categories for user documentation from ABB Robotics

The user documentation from ABB Robotics is divided into a number of categories. This listing is based on the type of information in the documents, regardless of whether the products are standard or optional.



Tip

All documents can be found via myABB Business Portal, www.abb.com/myABB.

Product manuals

Manipulators, controllers, DressPack, and most other hardware is delivered with a **Product manual** that generally contains:

- Safety information.
- Installation and commissioning (descriptions of mechanical installation or electrical connections).
- Maintenance (descriptions of all required preventive maintenance procedures including intervals and expected life time of parts).
- Repair (descriptions of all recommended repair procedures including spare parts).
- Calibration.
- Troubleshooting.
- Decommissioning.
- Reference information (safety standards, unit conversions, screw joints, lists of tools).
- Spare parts list with corresponding figures (or references to separate spare parts lists).
- References to circuit diagrams.

Technical reference manuals

The technical reference manuals describe reference information for robotics products, for example lubrication, the RAPID language, and system parameters.

Application manuals

Specific applications (for example software or hardware options) are described in **Application manuals**. An application manual can describe one or several applications.

An application manual generally contains information about:

- The purpose of the application (what it does and when it is useful).
- What is included (for example cables, I/O boards, RAPID instructions, system parameters, software).
- How to install included or required hardware.
- How to use the application.

Continues on next page

- Examples of how to use the application.

Operating manuals

The operating manuals describe hands-on handling of the products. The manuals are aimed at those having first-hand operational contact with the product, that is production cell operators, programmers, and troubleshooters.

This page is intentionally left blank

1 Safety

1.1 Safety information

1.1.1 Limitation of liability

Limitation of liability

Any information given in this manual regarding safety must not be construed as a warranty by ABB that the industrial robot will not cause injury or damage even if all safety instructions are complied with.

The information does not cover how to design, install and operate a robot system, nor does it cover all peripheral equipment that can influence the safety of the robot system.

In particular, liability cannot be accepted if injury or damage has been caused for any of the following reasons:

- Use of the robot in other ways than intended.
- Incorrect operation or maintenance.
- Operation of the robot when the safety devices are defective, not in their intended location or in any other way not working.
- When instructions for operation and maintenance are not followed as intended.
- Non-authorized design modifications of the robot.
- Repairs on the robot and its spare parts carried out by in-experienced or non-qualified personnel.
- Foreign objects.
- Force majeure.

Spare parts and equipment

ABB supplies original spare parts and equipment which have been tested and approved for their intended use. The installation and/or use of non-original spare parts and equipment can negatively affect the safety, function, performance, and structural properties of the robot. ABB is not liable for damages caused by the use of non-original spare parts and equipment.

1 Safety

1.1.2 Safety data

1.1.2 Safety data

Prevailing standards and directives

For the use of industrial robots, regulations must be fulfilled as described in the following standards and directives:

- EN ISO 10218-1:2011
- Machinery Directive 2006/42/EC

Performance level and category

EN ISO 10218-1 requires structure category 3 and performance level *PL d* on the robot, see EN ISO 13849-1.

Risk assessment

The results of a risk assessment performed on the robot and its intended application may determine that a safety-related control system performance other than that stated in ISO 10218 is warranted for the application.

The SISTEMA/ABB FSDT libraries contains details for the safety functions.

Performance level data

The performance level data for the respective controller variant is presented in section [Safety functions and safety related data for OmniCore E10 on page 42](#).

1.1.3 Requirements on personnel

General

Only personnel with appropriate training are allowed to install, maintain, service, repair, and use the robot. This includes electrical, mechanical, hydraulics, pneumatics, and other hazards identified in the risk assessment.

Persons who are under the influence of alcohol, drugs or any other intoxicating substances are not allowed to install, maintain, service, repair, or use the robot.

The plant liable must make sure that the personnel is trained on the robot, and on responding to emergency or abnormal situations.

Personal protective equipment

Use personal protective equipment, as stated in the instructions.

1 Safety

1.2.1 Safety signals in the manual

1.2 Safety signals and symbols

1.2.1 Safety signals in the manual







Introduction to safety signals

This section specifies all safety signals used in the user manuals. Each signal consists of:

- A caption specifying the hazard level (DANGER, WARNING, or CAUTION) and the type of hazard.
- Instruction about how to reduce the hazard to an acceptable level.
- A brief description of remaining hazards, if not adequately reduced.

Hazard levels

The table below defines the captions specifying the hazard levels used throughout this manual.

Symbol	Designation	Significance
	DANGER	Signal word used to indicate an imminently hazardous situation which, if not avoided, will result in serious injury.
	WARNING	Signal word used to indicate a potentially hazardous situation which, if not avoided, could result in serious injury.
	ELECTRICAL SHOCK	Signal word used to indicate a potentially hazardous situation related to electrical hazards which, if not avoided, could result in serious injury.
	CAUTION	Signal word used to indicate a potentially hazardous situation which, if not avoided, could result in slight injury.
	ELECTROSTATIC DISCHARGE (ESD)	Signal word used to indicate a potentially hazardous situation which, if not avoided, could result in severe damage to the product.
	NOTE	Signal word used to indicate important facts and conditions.

Continues on next page

Symbol	Designation	Significance
	TIP	Signal word used to indicate where to find additional information or how to do an operation in an easier way.

1 Safety

1.2.2 Safety symbols on controller labels

1.2.2 Safety symbols on controller labels

Introduction to safety symbols

Both the manipulator and the controller are marked with labels containing safety symbols and important information about the product. The purpose of the labels is to ensure personal safety for all personnel handling the robot, for example during installation, service, or operation.

The safety symbols are language independent, they only use graphics. The information labels contain information in text. See [Symbols and information on labels on page 20](#).



Note



The safety and information labels on the product must be observed.

Symbols and information on labels







Note

The descriptions in this section are generic, the labels can contain additional information such as values.

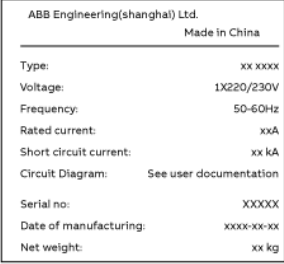
Label	Description
 xx1400001152	Read the user manual before use.
 xx2100000104	The robot is delivered to start in automatic mode
 xx1800000835	CE label

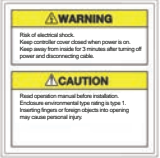
Continues on next page

Label	Description
 <p>xx1400002061</p>	<p>UL certified (robot with controller)</p>
 <p>xx1900001805</p>	<p>Rating label (example)</p>
 <p>xx1400001151</p>	<p>Electrical shock</p>
 <p>xx1800000836</p>	<p>Warning & caution label</p>
 <p>xx1400001156</p>	<p>High voltage inside the module even if the main switch is in the OFF position.</p>
 <p>xx1400001162</p>	<p>ESD sensitive components inside the controller.</p>

1 Safety

1.3.1 Protective stop and emergency stop

1.3 Robot stopping functions

1.3.1 Protective stop and emergency stop

Robot stopping functions

The robot has protective and emergency stop functions (stop category 0 or 1, in accordance with IEC 60204-1).

Stop category 0	As defined in IEC 60204-1, stopping by immediate removal of power to the machine actuators.
Stop category 1	As defined in IEC 60204-1, a controlled stop with power available to the machine actuators to achieve the stop and then removal of power when the stop is achieved.

A stop function, protective or emergency stop, has a default setting for the stop category, see [Inputs to initiate a protective stop or an emergency stop on page 22](#).

The default stop category for a protective or emergency stop can be re-configured. Activation of external safety rated devices, connected to the robot controller through dedicated discrete safety inputs or safety protocols, will initiate these stop functions.

Inputs to initiate a protective stop or an emergency stop

Inputs to initiate a stop function	Description	Default stop category	Stop category reconfigurable
Emergency Stop (ES)	Input to initiate the emergency stop function. The <i>Emergency Stop</i> function is initiated in both automatic and manual mode.	Stop category 0 For deviations, see the product manual for the manipulator.	Yes
Automatic Stop and General Stop (AS/GS)	Input to initiate the protective stop function, which can be configured to be either <i>Automatic Stop</i> or <i>General Stop</i> . When configured as <i>Automatic Stop</i> , the protective stop function is only initiated in automatic mode. When configured as <i>General Stop</i> , the protective stop function is initiated in both manual mode and automatic mode.	Stop category 1	Yes



Note

For OmniCore, the default configuration for the protective stop function triggered by the protective stop input is *Automatic Stop*.

For example, a safety rated output from a presence sensing device, connected to AS / GS, a dedicated discrete protective stop input on the robot controller, will when the protective stop function is configured as Automatic Stop (AS) initiate the protective stop function in automatic mode only.

Continues on next page

The emergency stop function is a complementary protective measure and shall not be applied as a substitute for safeguarding measures or safety functions.



Note

For OmniCore, a safety input used to initiate a protective stop must remain active for at least 100 ms.

Stop category configuration for OmniCore

The stop category configuration is done in RobotStudio, in the tool *Visual Safety*.

1 Safety

1.3.2 About emergency stop

1.3.2 About emergency stop

The emergency stop

The purpose of the emergency stop function is to avert actual or impending emergency situations arising from the behavior of persons or from an unexpected hazardous event.

The emergency stop function is to be initiated by a single human action.

The emergency stop function is a complementary protective measure and shall not be applied as a substitute for safeguarding measures and other functions or safety functions.

The effect of an activated emergency stop device is sustained until the actuator of the emergency stop device has been disengaged. This disengagement is only possible by an intentional human action on the device where the command has been initiated. The disengagement of the emergency stop device shall not restart the machinery but only permit restarting.



Note

The emergency stop device on the FlexPendant is operational when the robot is powered. Indicators to be used to verify that the robot is powered are the main switch on the cabinet or the LED indicator on the cabinet when robot is in Motors On Mode.

Recover from emergency stop

- 1 Inspect the machinery in order to detect the reason for the emergency stop device actuation.
- 2 Locate and disengage the emergency stop device or devices that initiated the emergency stop function.

1.3.3 Enabling device and hold-to-run functionality

Three-position enabling device

**CAUTION**

The person using the three-position enabling device is responsible to observe the safeguarded space for hazards due to robot motion and any other hazards related to the robot.

The three-position enabling device is located on the FlexPendant. When continuously held in center-enabled position, the three-position enabling device will permit robot motion and any hazards controlled by the robot. Release of or compression past the center-enabled position will stop the robot motion.

**CAUTION**

For safe use of the three-position enabling device, the following must be implemented:

- The three-position enabling device must never be rendered inoperational in any way.
- If there is a need to enter safeguarded space, always bring the FlexPendant. This is to enforce single point of control.

Hold-to-run function in manual high speed mode

The hold-to-run function for manual high speed allows movement in conjunction with the three-position enabling device when the button connected to the function is actuated manually. This hold-to-run function can only be used in manual high speed mode. In case of hazard, release or compress the three-position enabling device.

How to use the hold-to-run function for manual high speed mode is described in the operating manual for the controller.

1 Safety

1.4.1 About the manual mode

1.4 Robot operating modes

1.4.1 About the manual mode

The manual mode

Manual mode is a control state that allows for the direct control by an operator. The operator will through positioning the three-position enabling device to the center-position allow for movement of the manipulator.

There are two manual modes:

- Manual reduced speed
- Manual high speed (optional)

Safeguard mechanisms

Protective stop function initiated by

- Three-position enabling device (release of or compression past the center-enabled position)
- General Stop, GS (the dedicated input, GS, or the dedicated input AS/GS configured to GS, see actual controller)

The mode manual reduced speed

The mode manual reduced speed, is used for jogging, teaching, programming and program verification of the robot; it may be the mode selected when performing some maintenance tasks.

In manual reduced speed mode the movement of the TCP is limited to 250 mm/s. In addition, there is a limitation on the maximum allowed speed for each axis.

Manual control of the robot from inside the safeguarded space shall be performed through the FlexPendant.



WARNING

Wherever possible, the manual mode of operation shall be performed with all persons outside the safeguarded space.

Tasks normally performed in mode manual reduced speed

The following tasks are normally performed in manual reduced speed mode.

- Set or reset I/O signals
- Creating and editing RAPID programs
- Modify system parameter values
- Starting, stepping, and stopping program execution
- Jog the manipulator
- Teach or tune programmed manipulator positions

The mode manual high speed

The mode manual high speed, is used for program verification only.

Continues on next page

The three-position enabling switch must be pressed to the center-position and the hold-to-run button must be pressed to allow start of program execution, for example, execute movement instructions.

In manual high speed, the initial speed of the movement, does not exceed 250 mm/s, that is limited to a percentage of the programmed speed. The speed can be manually adjusted in steps up to the programmed speed.

When the three-position enabling device is released or fully compressed, the speed is reset to the initial speed, that is, not exceeding 250 mm/s.



WARNING

Wherever possible, the manual mode of operation shall be performed with all persons outside the safeguarded space.

Tasks normally performed in mode manual high speed

The following tasks are normally performed in manual high speed mode.

- Program verification
- Setting program pointer (to Main, to routine, to cursor, to service routine, etc.)
- Starting and stopping program execution
- Stepping program execution
- Manually adjusting speed (0–100%)

1 Safety

1.4.2 About the automatic mode

1.4.2 About the automatic mode

The automatic mode

Automatic mode is an operating mode in which the robot operates in accordance with the task program(s).

Tasks normally performed in automatic mode

The following tasks are typically performed in automatic mode:

- Start and stop of program execution.
- Increase or decrease the speed in between zero and programmed speed.
- Restore backups. Only possible when robot is at stop.
- Load, start, stop, and modify RAPID programs through remote clients.

Safeguard mechanisms

Protective stop function initiated by

- Automatic Stop, AS (the dedicated input, AS, or the dedicated input AS/GS configured to AS, see actual controller)
- General Stop, GS (the dedicated input, GS, or the dedicated input AS/GS configured to GS, see actual controller)



Note

Prior to allowing the robot to operate in automatic mode, ensure that any suspended safeguards, are returned to full functionality.

1.5 Safety during installation and commissioning

National or regional regulations

The integrator of the robot system is responsible for the safety of the robot system.

The integrator is responsible that the robot system is designed and installed in accordance with the safety requirements set forth in the applicable national and regional standards and regulations.

The integrator of the robot system is required to perform a risk assessment.

Layout

The robot integrated to a robot system shall be designed to allow safe access to all spaces during installation, operation, maintenance, and repair.

If robot movement can be initiated from an external control panel then an emergency stop must also be available.

If the manipulator is delivered with mechanical stops, these can be used for reducing the working space.

A perimeter safeguarding, for example a fence, shall be dimensioned to withstand the following:

- The force of the manipulator.
- The force of the load handled by the robot if dropped or released at maximum speed.
- The maximum possible impact caused by a breaking or malfunctioning rotating tool or other device fitted to the robot.

The maximum TCP speed and the maximum velocity of the robot axes are detailed in the section *Robot motion* in the product specification for the respective manipulator.

Consider exposure to hazards, such as slipping, tripping, and falling.

Hazards due to the working position and posture for a person working with or near the robot shall be considered.

Hazards due to noise emission from the robot needs to be considered.

Consider hazards from other equipment in the robot system, for example, that guards remain active until identified hazards are reduced to an acceptable level.

Allergenic material

See [Environmental information on page 206](#) for specification of allergenic materials in the product, if any.

Securing the robot to the foundation

The robot must be properly fixed to its foundation/support, as described in the respective product manual.

When the robot is installed at a height, hanging, or other than mounted directly on the floor, there will be additional hazards.

Continues on next page

1 Safety

1.5 Safety during installation and commissioning

Continued

Using lifting accessories and other external equipment

Ensure that all equipment used during installation, service and all handling of the robot are in correct condition for the intended use.

Electrical safety

Incoming mains must be installed to fulfill national regulations.

The power supply wiring to the robot must be sufficiently fused and if necessary, it must be possible to disconnect it manually from the mains power.

The power to the robot must be turned off with the main switch and the mains power disconnected when performing work inside the controller cabinet. Lock and tag shall be considered.

Hazards due to stored electrical energy in the controller must be considered.

Harnesses between controller and manipulator shall be fixed and protected to avoid tripping and wear.

Wherever possible, power on/off or rebooting the robot controller shall be performed with all persons outside the safeguarded space.



Note

Use a CARBON DIOXIDE (CO₂) extinguisher in the event of a fire in the robot.

Safety devices

The integrator is responsible for that the safety devices necessary to protect people working with the robot system are designed and installed correctly.

When integrating the robot with external devices to a robot system:

- The integrator of the robot system must ensure that emergency stop functions are interlocked in accordance with applicable standards.
- The integrator of the robot system must ensure that safety functions are interlocked in accordance with applicable standards.

Other hazards

A robot may perform unexpected limited movement.



WARNING

Manipulator movements can cause serious injuries on users and may damage equipment.

The risk assessment should also consider other hazards arising from the application, such as, but not limited to:

- Water
- Compressed air
- Hydraulics

End-effector hazards require particular attention for applications which involve close human collaboration with the robot.

Continues on next page

Verify the safety functions

Before the robot system is put into operation, verify that the safety functions are working as intended and that any remaining hazards identified in the risk assessment are mitigated to an acceptable level.

1 Safety

1.6 Safety during operation

1.6 Safety during operation

Automatic operation

Verify the application in the operating mode manual reduced speed, before changing mode to automatic and initiating automatic operation.

Lock and change of operating mode

To prevent hazard, it is the responsibility of the integrator to make sure that keys used to lock or change the operating mode are handled only by authorized personnel.

Safety devices not in use

Safety devices that are not connected to the robot or robot system cannot initiate a protective or emergency stop. These must be stored out of sight so that they cannot be mistaken for being in use.

1.7 Safety during maintenance and repair

General

Corrective maintenance must only be carried out by personnel trained on the robot. Maintenance or repair must be done with all electrical, pneumatic, and hydraulic power switched off, that is, no remaining hazards.

Never use the robot as a ladder, which means, do not climb on the controller, manipulator, including motors, or other parts. There are hazards of slipping and falling. The robot might be damaged.

Make sure that there are no tools, loose screws, turnings, or other unexpected parts remaining after maintenance or repair work.

When the work is completed, verify that the safety functions are working as intended.

Hot surfaces

Surfaces can be hot after running the robot, and touching these may result in burns. Allow the surfaces to cool down before maintenance or repair.

Hazards related to batteries

Under rated conditions, the electrode materials and liquid electrolyte in the batteries are sealed and not exposed to the outside.

There is a hazard in case of abuse (mechanical, thermal, electrical) which leads to the activation of safety valves and/or the rupture of the battery container. As a result under certain circumstances, electrolyte leakage, electrode materials reaction with moisture/water or battery vent/explosion/fire may follow.

Do not short circuit, recharge, puncture, incinerate, crush, immerse, force discharge or expose to temperatures above the declared operating temperature range of the product. Risk of fire or explosion.

Operating temperatures are listed in [Operating conditions on page 39](#).

See safety instructions for the batteries in *Material/product safety data sheet - Battery pack (3HAC043118-001)*.

Related information

See also the safety information related to installation and operation.

1 Safety

1.8 Safety during troubleshooting

1.8 Safety during troubleshooting

General

When troubleshooting requires work with power switched on, special considerations must be taken:

- Safety circuits might be muted or disconnected.
- Electrical parts must be considered as *live*.
- The manipulator can move unexpectedly at any time.



DANGER

Troubleshooting on the controller while powered on must be performed by personnel trained by ABB or by ABB field engineers.

A risk assessment must be done to address both robot and robot system specific hazards.

Related information

See also the safety information related to installation, operation, maintenance, and repair.

1.9 Safety during decommissioning

General

See section [Decommissioning on page 205](#).

If the robot is decommissioned for storage, take extra precaution to reset safety devices to delivery status.

This page is intentionally left blank

2 Controller description

2.1 OmniCore E10

About OmniCore E10

The OmniCore E10 controller is part of the modular controller family. It will target mainly on 3C Electronics robot market.

It is used to control an ABB manipulator used in industrial applications such as material handling and machine tending.

2 Controller description

2.2 Technical data for OmniCore E10 controller

2.2 Technical data for OmniCore E10 controller

Overview of the controller

OmniCore E10 is intended to be used in industrial environment.



xx2100001294

	Reference to circuit diagram	OmniCore E10
Power inlet switch	Q0	Baseline
Power inlet connector	X0	Baseline
Motor connector	X1	Baseline
Manipulator signal connector (SMB)	X2	Baseline
I/O interface	X5	Baseline
Customer optional power input	X6	Baseline
HMI connector (TPU)	HMI	Baseline
Customer safety interface	X9	Baseline
Drive unit	T4	Baseline
Power unit	A1	Baseline
Computer and logic unit	A2	Baseline
Small fan	G1/G2	Baseline

Dimensions

Parameter	Value
Width	445 mm
Depth	340 mm
Height	105 mm (With foot) 89 mm (Without foot)

Continues on next page

2 Controller description

2.2 Technical data for OmniCore E10 controller

Continued

Weight

Controller	Weight
OmniCore E10	12 kg



Note

The weight does not include any mounting kits fitted on the controller.

Transportation and storage conditions

Parameter	Value
Minimum ambient temperature	-25 °C (-13 °F)
Maximum ambient temperature	+55 °C (+131 °F)
Maximum ambient temperature (less than 24 hrs)	+70 °C (+158 °F)
Vibration	Max. Grms = 4 m/s ² (X & Y axis), Grms = 12.8 m/s ² (Z axis)
Bumps	Max. 5 g = 50 m/s ² (11 ms)

After storage, the operating conditions inside the controller must be met for at least 6 hours before switching on the controller (see [Operating conditions on page 39](#)).

The robot controller shall be stored according to its IP classification (IP20), that is, indoors, in an environment that is dry and dust-free. In addition, wind, temperature fluctuations, and condensation shall be avoided.

See also *Product specification - OmniCore E line*.

Operating conditions

The table shows the allowed operating conditions for the controller.

Parameter	Value
Minimum ambient temperature	+5 °C (+41 °F)
Maximum ambient temperature	+45 °C (+113 °F)
Maximum ambient altitude	2,000 m
Vibration	Max. Grms = 2.86 m/s ² (X, Y, Z axis)
Bumps	Max. 5 g = 50 m/s ² (11 ms)



Note

The humidity conditions shall apply with the environmental conditions EN 60721-3-3, climatic class 3K3. For temperatures 0-30 °C, the relative humidity must not exceed 85%. For temperatures exceeding 30 °C, the absolute humidity must not exceed 25g/m³.

If the environmental conditions in EN 60721-3-3, climatic class 3K3, are not possible to meet at the installation site, desiccant bags can be placed inside the controller to achieve corresponding conditions. The desiccant bags must be replaced regularly to maintain approved operating conditions.

Continues on next page

2 Controller description

2.2 Technical data for OmniCore E10 controller

Continued

Protection classes

	Protection class
Controller cabinet, inner compartment for electronics	IP20
FlexPendant	IP65

Airborne noise level

Data	Description	Note
Airborne noise level	The sound pressure level one meter away from each surface of the controller.	Controller in Motors On Mode: < 53 dB(A) Leq Controller in Standby Mode: < 44 dB(A) Leq

Power supply

Mains	Value
Voltage for OmniCore E10	220/230 VAC, 1 phase 100-230 VAC, 1 phase ⁱ
Voltage tolerance	+10%, -15% +10%, -10% ⁱ
Frequency	50/60 Hz
Frequency tolerance	±3%
Short circuit current rating	According to rating label.  Note For installations according to UL requirements, short circuit current rating is 5 kA.

ⁱ For IRB 1100 and IRB 1090 controller.



Note

The 2 phases (180-degree phase shift, with grounded neutral), also called Single-phase three-wire system in North America, can be supported by this controller.

Line fusing

There is no integrated fuse inside the OmniCore E10 controller. Add an external fuse (time-delay) or circuit breaker (class K) according to full load current, as marked on the controller nameplate. The following table shows the recommended rating for an external fuse or circuit breaker.

Robot	Description	Current
IRB 910INV	220/230 VAC, 1 phase	10 A
IRB 920	220/230 VAC, 1 phase	10 A
IRB 930	220/230 VAC, 1 phase	10 A
IRB 1010	100-230 VAC, 1 phase	10 A

Continues on next page

2 Controller description

2.2 Technical data for OmniCore E10 controller *Continued*

Robot	Description	Current
IRB 1090	100-230 VAC, 1 phase	10 A
IRB 1100	100-230 VAC, 1 phase	10 A
IRB 1200	100-230 VAC, 1 phase	10 A
IRB 1300	220/230 VAC, 1 phase	10 A

Residual current

An external earth fault protection (residual current device, RCD) is required based on the following data:

Robot	Residual Current in controller (mA)
IRB 910INV	< 30 mA
IRB 920	< 30 mA
IRB 930	< 30 mA
IRB 1010	< 30 mA
IRB 1090	< 30 mA
IRB 1100	< 30 mA
IRB 1200	< 30 mA
IRB 1300	< 30 mA



Note

The integrator is responsible to address local electrical requirements.

2 Controller description

2.3 Safety functions and safety related data for OmniCore E10

2.3 Safety functions and safety related data for OmniCore E10

Basic Safety Functions

The safety data is valid for the Basic Safety Functions for applicable ABB manipulators¹.

The OmniCore E10 provides safety with structure *category 3* with performance level *d* according to EN ISO 13849-1. This fulfils the safety performance requirement as stated in the robot safety standard EN ISO 10218-1.

Safety Functions	MTTF _D [years]	DC [%]	PFH _D [1/hour]
Emergency stop of robot from FlexPendant (TPU)	92	94	4.94E-08
Protective stop of robot through Enabling Device	79	95	6.62E-08
Mirror Emergency stop state of robot triggered from External ESTOP	232	90	4.29E-08
Mirror Emergency stop state of robot triggered from FlexPendant (TPU)	190	92	4.29E-08
Emergency stop of robot	101	94	4.29E-08
Protective stop of robot	101	94	4.29E-08

Related information

[Safety data on page 16](#)

¹ The supported manipulators are listed in *Product specification - OmniCore E line*.

2.4 The unit is sensitive to ESD

Description

ESD (electrostatic discharge) is the transfer of electrical static charge between two bodies at different potentials, either through direct contact or through an induced electrical field. When handling parts or their containers, personnel not grounded may potentially transfer high static charges. This discharge may destroy sensitive electronics.

Safe handling

Use one of the following alternatives:

- Use a wrist strap. The wrist strap button is located inside the controller.
Wrist straps must be tested frequently to ensure that they are not damaged and are operating correctly.
- Use an ESD protective floor mat.
The mat must be grounded through a current-limiting resistor.
- Use a dissipative table mat.
The mat should provide a controlled discharge of static voltages and must be grounded.

Wrist strap button

The location of the wrist strap button is shown in the following illustration.

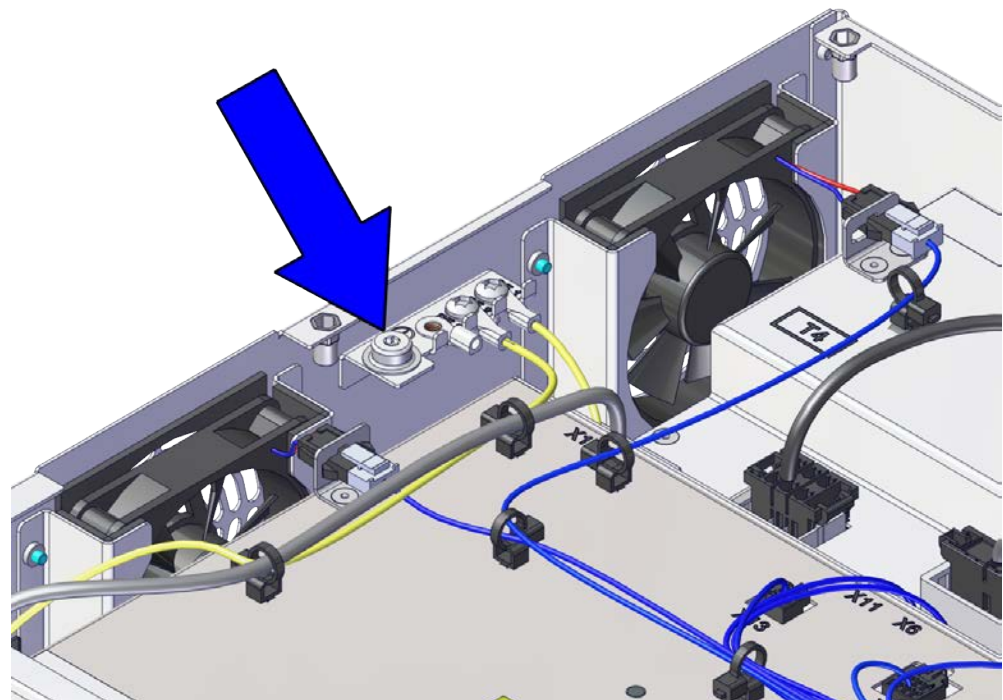

xx2100001295

2 Controller description

2.5 Handling of FlexPendant

2.5 Handling of FlexPendant

Detached FlexPendant

A FlexPendant that is not connected to the robot must be stored out of sight so that it cannot be mistaken for being in use.

Handling and cleaning

- The FlexPendant may only be used for the purposes mentioned in this manual.
- Always use the hand-strap while holding the FlexPendant.
- Handle with care. Do not drop, throw, or give the FlexPendant strong shock. It can cause breakage or failure.
- If the FlexPendant is subjected to shock, always verify that the safety functions (three-position enabling device and emergency stop) work and are not damaged.
- Always use and store the FlexPendant in such a way that the cable does not become a tripping hazard.
- When not using the device, place it in its holder.
- Never use sharp objects (such as screwdriver or pen) for operating the touch screen. This could damage the touch screen. Instead use your finger or a stylus.
- Never clean the FlexPendant with solvents, scouring agent, or scrubbing sponges.
See the product manual for the robot controller, section *Cleaning the FlexPendant*.
- Always close the protective cap on the USB port when no USB device is connected. The port can break or malfunction if exposed to dirt or dust.
- Do not squeeze and thus damage the cable.
- Do not lay the cable over sharp edges.



CAUTION

The FlexPendant touch screen is made of glass. If the device is dropped on a hard surface or receives a significant impact the glass could break. To reduce the risk of cuts if the glass chips or cracks, do not touch or attempt to remove the broken glass.

FCC statement

Changes or modification to the FlexPendant not expressly approved by ABB will void the user's authority to operate the equipment.

This device complies with Part 15 of the FCC Rules. Operation is subject to the following two conditions:

- 1 This device may not cause harmful interference, and
- 2 This device must accept any interference received, including interference that may cause undesired operation.

2.6 Network security

Network security

This product is designed to be connected to and to communicate information and data via a network interface. It is your sole responsibility to provide, and continuously ensure, a secure connection between the product and to your network or any other network (as the case may be).

You shall establish and maintain any appropriate measures (such as, but not limited to, the installation of firewalls, application of authentication measures, encryption of data, installation of anti-virus programs, etc) to protect the product, the network, its system and the interface against any kind of security breaches, unauthorized access, interference, intrusion, leakage and/or theft of data or information. ABB Ltd and its entities are not liable for damage and/or loss related to such security breaches, any unauthorized access, interference, intrusion, leakage and/or theft of data or information.

2 Controller description

2.7 Open source and 3rd party components

2.7 Open source and 3rd party components

Open source and 3rd party components

ABB products use software provided by third parties, including open source software. The following copyright statements and licenses apply to various components that are distributed inside the ABB software. Each ABB product does not necessarily use all of the listed third party software components. Licensee must fully agree and comply with these license terms or the user is not entitled to use the product. Start using the ABB software means accepting also referred license terms. The third party license terms apply only to the respective software to which the license pertains, and the third party license terms do not apply to ABB products. With regard to programs provided under the GNU general public license and the GNU lesser general public license licensor will provide licensee on demand, a machine-readable copy of the corresponding source code. This offer is valid for a period of three years after delivery of the product.

ABB software is licensed under the ABB end user license agreement, which is provided separately.

RobotWare

For RobotWare, there is license information in the folder \licenses in the RobotWare distribution package.

OpenSSL

This product includes software developed by the OpenSSL Project for use in the OpenSSL Toolkit. (<http://www.openssl.org/>)

This product includes cryptographic software written by Eric Young (ey@cryptsoft.com).

This product includes software written by Tim Hudson (tjh@cryptsoft.com).

CTM

For OleOS, the Linux based operating system used on the conveyor tracking module (CTM), a list of copyright statements and licenses is available in the file `/etc/licenses.txt` located on the CTM board and accessible via the console port or by downloading the file over SFTP.

For the CTM application, a list of copyright statements and licenses is available in the file `/opt/ABB.com/ctm/licenses.txt` located on the CTM board and accessible via the console port or by downloading the file over SFTP.

2.8 ABB Connected Services (ABB Ability)



Note

The content of this section is only available in English.



Note

ABB Connected Services is the new name for the functionality previously known as ABB Ability. During a period of time, both names will appear in and on our products.

The OmniCore™ controller hardware is delivered with a standard mobile connection (Cellular data connection), or WIFI modem and/or Ethernet connection².

Cellular data connection

If the ABB Connected Services™ OmniCore™ controller hardware is delivered together with a standard, free of charge (machine-to-machine or M2M) cellular data connection, it will automatically establish a connection to the ABB Connected Services™ digital platform once the power switch of the ABB Connected Services™ OmniCore™ controller hardware has been turned on and has been connected.

After the establishment of the connection there will be a data flow from the OmniCore™ controller hardware to the ABB Connected Services™ digital platform.

ABB does not warrant or guarantee an available, stable, uninterrupted, and interference free connection through the standard cellular data connection. This is dependent on the availability and quality of the cellular data signal as provided by the telecommunications carrier on the location where the ABB Connected Services™ OmniCore™ hardware is installed. The cellular data connection is to be used solely in connection with the ABB Connected Services™ OmniCore™ controller hardware and excludes, without limitation, voice services, web browsing, music downloading and other services that are not traditionally considered as machine to machine (M2M), but human-oriented telecommunication services.

ABB has established and maintains a formal information and cybersecurity procedures which includes commercially reasonable technical and organizational measures, in order to protect the data against security breaches, accidental or unlawful destruction, loss, alteration, and unauthorized disclosure of, or access to the data.

The cellular data connection is not required for the operation of the hardware and the connectivity settings can be adjusted and turned off at any given time. Detailed information on the mobile connection is further described in the service description that can be downloaded from the following web location:

<https://share.library.abb.com/api/v4?cid=9AAC910011&dk=Manual>

² For OmniCore E10, only Ethernet connection is available.

Continues on next page

2 Controller description

2.8 ABB Connected Services (ABB Ability)

Continued

Data

ABB will not acquire any right, title and interest in the data other than the rights granted by Customer to ABB, but ABB will have the right to collect, store, aggregate, analyze or otherwise use the data for (i) providing and maintaining the hardware, services and/or the ABB software to Customer; (ii) preventing, detecting and repairing problems related to the security and/or the operation of the hardware, the platform, software; (iii) improving and developing existing services, technologies, products and/or software and developing new services, technologies, products and/or software, and all improvements and developments (including all resulting intellectual property Rights) are exclusively owned by us. In addition, we have the right to use the data for benchmarking purposes if and to the extent it is anonymized or non-confidential.

ABB Connected Services™

For as far as the robot installation includes ABB Connected Services™, this agreement is entered pursuant to and governed by the ABB Connected Services™ General Terms and Conditions.

ABB Connected Services™ Terms and Conditions:

<https://ability.abb.com/terms>

Special Terms and Conditions for ABB Connected Services™:

<https://new.abb.com/products/robotics/service/robot-registration>

3 Installation and commissioning

3.1 Introduction to installation and commissioning

General

This chapter contains assembly instructions and information for installing the OmniCore E10 at the working site.

See also the product manual for the manipulator.

The installation must be done by qualified installation personnel in accordance with the safety requirements set forth in the applicable national and regional standards and regulations.

The technical data is detailed in section [Technical data for OmniCore E10 controller on page 38](#).

Safety information

Before any installation work is commenced, all safety information must be observed. There are general safety aspects that must be read through, as well as more specific safety information that describes the danger and safety risks when performing the procedures. Read the chapter [Safety on page 15](#) before performing any installation work.



Note

Always connect the OmniCore E10 and the robot to protective earth and residual current device (RCD) before connecting to power and starting any installation work.

3 Installation and commissioning

3.2 Installation activities

3.2 Installation activities

Main steps for installing the controller

Use the following main steps to install and connect the controller.

	Action	Described in
1	Unpack the controller.	Unpacking the controller on page 51.
2	Place the controller in position and bolt it to the ground.	On-site installation on page 53.
3	Connect the manipulator to the controller.	Connecting the manipulator to the controller on page 77.
4	Attach the FlexPendant to the controller.	Attaching the FlexPendant on page 84
5	Install an external circuit breaker or fuse.	Connecting incoming mains and protective earth to the controller on page 79
6	Connect the cabinet to protective earth.	Connecting incoming mains and protective earth to the controller on page 79
7	Install a residual current device (RCD).	Connecting incoming mains and protective earth to the controller on page 79
8	Connect incoming mains to the controller.	Connecting incoming mains and protective earth to the controller on page 79
9	Connect safeguards to the controller.	Customer safety interface - X9 on page 89.
10	Connect, for example, Ethernet, PC, and other connections.	How to connect industrial networks, for example PROFINET, is described in the respective application manual. How to connect to a network and a PC is described in section Ethernet networks on OmniCore on page 85 . See also <i>Operating manual - RobotStudio</i> . See also Descriptions for connectors on page 87 .
11	Install options and add-ons (optional).	Installing add-on devices on page 106.
12	Initial test before commissioning.	Initial test before commissioning on page 110.



Note

If the controller replaces another OmniCore controller, see *Operating manual - Integrator's guide OmniCore* for descriptions of how to transfer software configurations.

3.3 Transporting and handling

3.3.1 Unpacking

Unpacking the controller

	Action
1	Make a visual inspection of the packaging and make sure that nothing is damaged.
2	Remove the packaging.
3	<p>Check for any visible transport damage.</p> <p> Note Stop unpacking and contact ABB if transport damage is found.</p>
4	Clean the unit with a lint-free cloth, if necessary.
5	Make sure that the lifting accessory used (if applicable) is suitable to handle the weight of the controller.
6	If the controller is not installed directly, it must be stored as described in Transportation and storage conditions on page 39 .
7	Make sure that the expected operating environment of the controller conforms to the specifications as described in Operating conditions on page 39 .
8	The controller can be taken to its installation site as described in section On-site installation on page 53 .

3 Installation and commissioning

3.3.2 Storing

3.3.2 Storing

Storing the controller

For storing, see [Transportation and storage conditions on page 39](#).

3.4 On-site installation

3.4.1 Required installation space

Dimensions

The following illustration shows the required installation space for the OmniCore E10 controller. A free space is required for connecting ABB cables. Do not place any cables over the left and right covers as it leads to inefficient cooling.

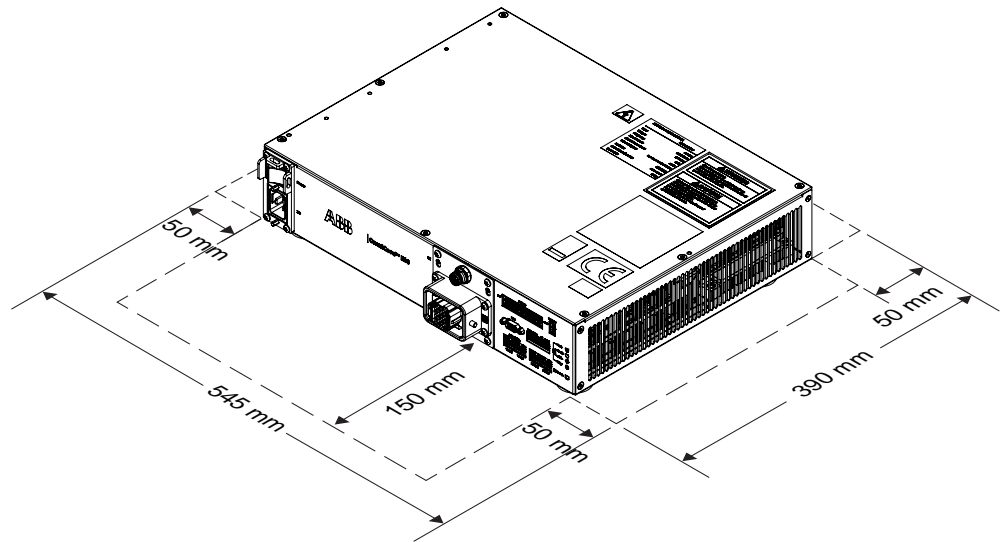

xx2100001296

Free space	Front	Back	Left	Right
Base-mounted	150 mm	50 mm	50 mm	50 mm
Rack-mounted	150 mm	50 mm	50 mm	50 mm

Continues on next page

3 Installation and commissioning

3.4.1 Required installation space

Continued

Foot dimensions

The following illustration shows the dimensions between the feet of the OmniCore E10 controller, as seen from below.

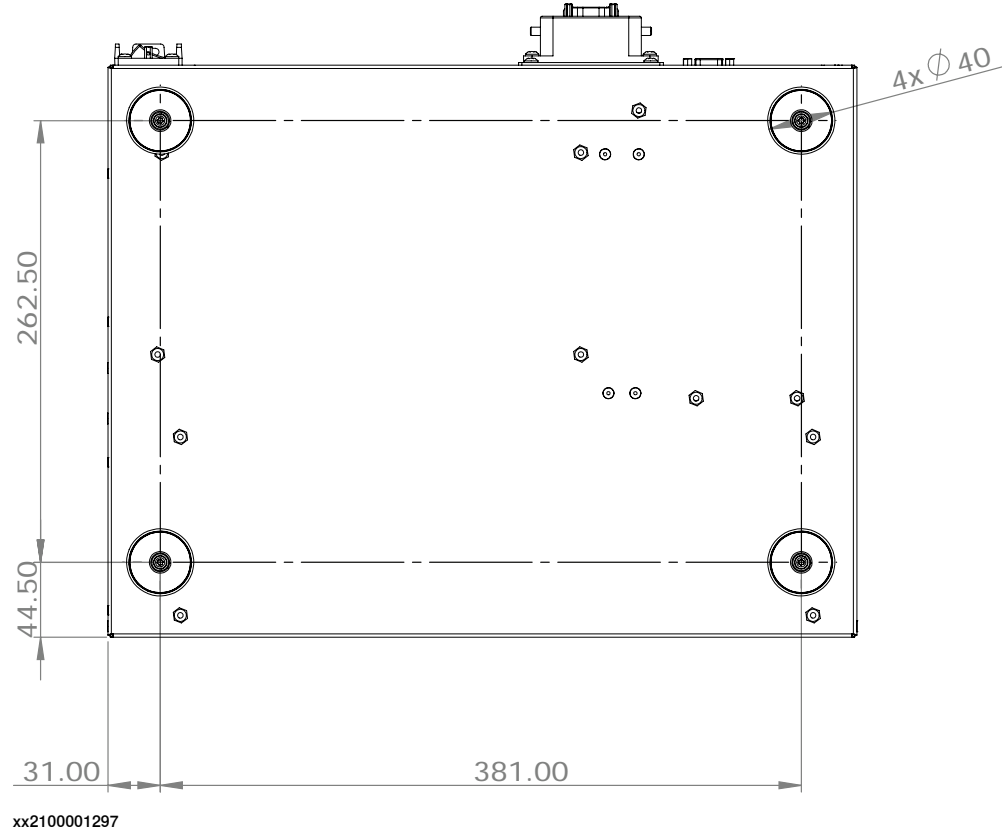

- The feet should only be used for positioning, not for mounting or fastening.

3.4.2 Mounting the controller with 19" rack mounting kit

General

The OmniCore E10 controller is designed to fit in a 19" cabinet.

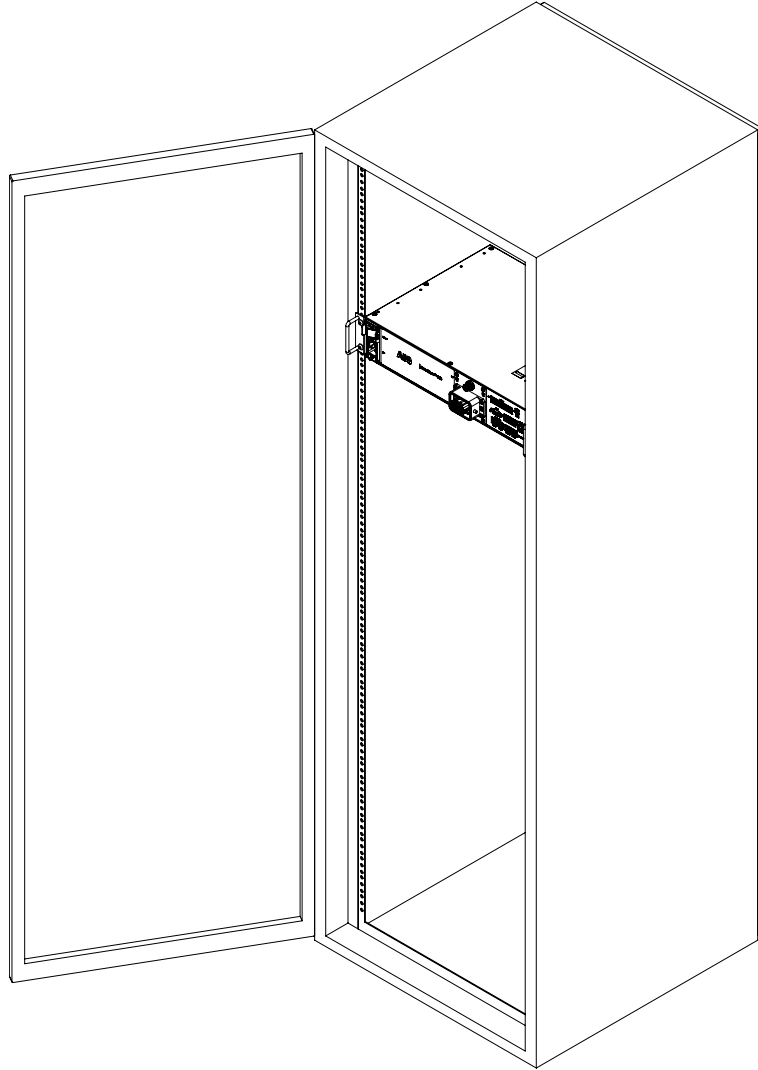

xx2100001562



Note

If the controller is installed in a rack (cabinet), it must be fastened in a way that prevents distortion of the controller cabinet. Preferably with angle bars along the entire side edges of the controller.

Required equipment

Equipment	Information
Mounting kit	3HAC077631-001
Standard toolkit	See Standard toolkit for controller on page 212 .

Continues on next page

3 Installation and commissioning

3.4.2 Mounting the controller with 19" rack mounting kit

Continued

Installing the 19" rack mounting kit to the controller

Use this procedure to install the controller in a 19" cabinet.

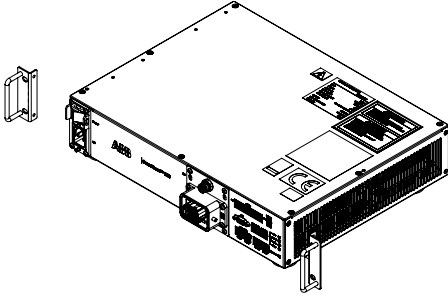
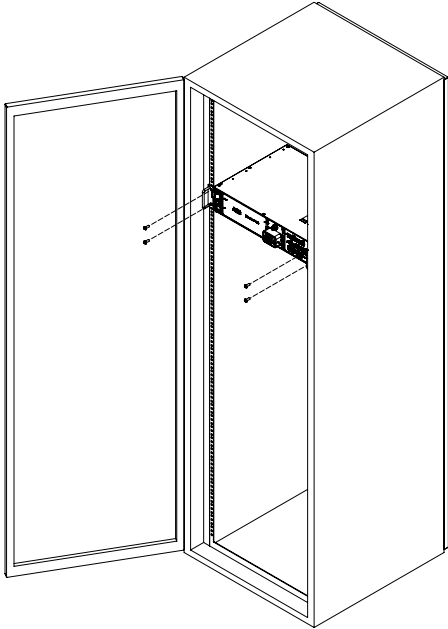
	Action	Information
1	Remove the screws on the right and left sides.	 xx2100001311
2	Assemble the mounting kit.	
3	Place the controller into the 19" cabinet and fasten it with the screws.	Torx pan head screw M6x16 (4 pcs) Tightening torque: 1.7-1.8 Nm  xx2100001563

3.4.3 Mounting the controller with design front mounting kit [3001-3]

General

The OmniCore E10 controller is designed to fit as a desk version, that can have a design front mounting kit.

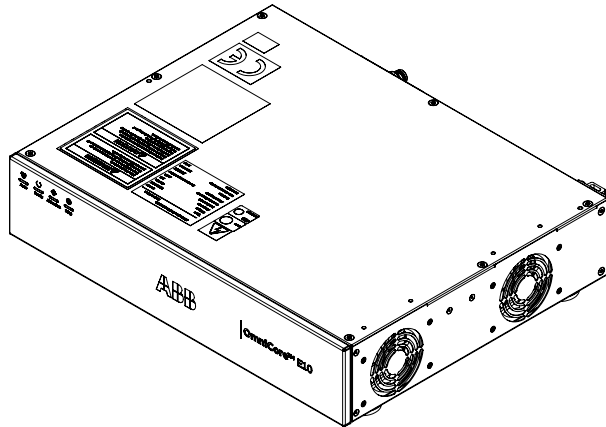

xx2200000747



Tip

Only the version with the hole plug can fit with the design front mounting kit [3001-3].

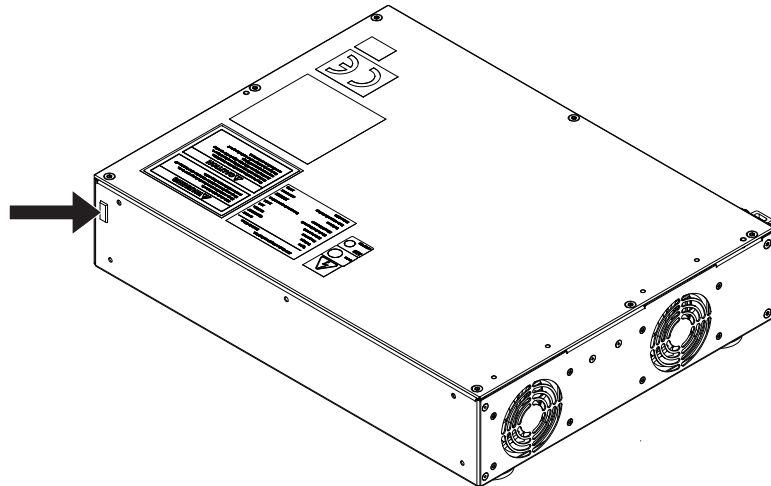

xx2300000249

Required equipment

Equipment	Information
Design front mounting kit	3HAC082539-001
Harness LED status	3HAC081613-001

Continues on next page

3 Installation and commissioning

3.4.3 Mounting the controller with design front mounting kit [3001-3]

Continued

Equipment	Information
Cabinet base assembly	If your OmniCore E10 controller is the version WITHOUT hole plug, contact ABB to get support for the design front installation.
Standard toolkit	See Standard toolkit for controller on page 212 .

Procedure

Use this procedure to install the desktop mounting kit on the controller.

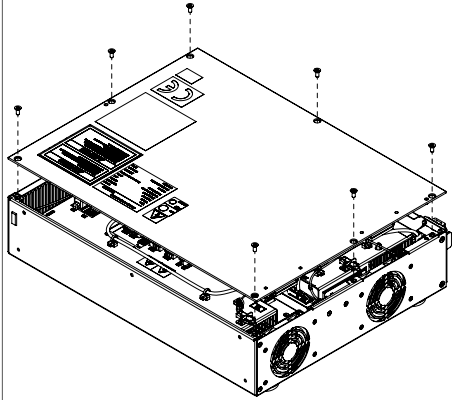
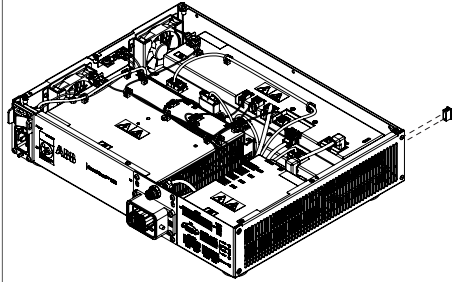
	Action	Info/illustration
1	Remove the top cover from the controller.	 <p>xx220000746</p>
2	Press the hole plug from inside of the controller.	 <p>xx220000742</p>

Continues on next page

3 Installation and commissioning

3.4.3 Mounting the controller with design front mounting kit [3001-3]

Continued

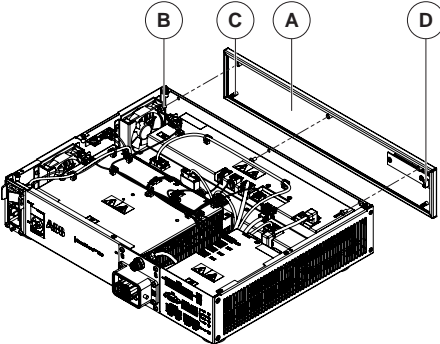
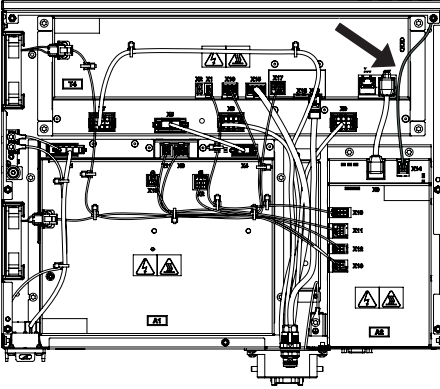
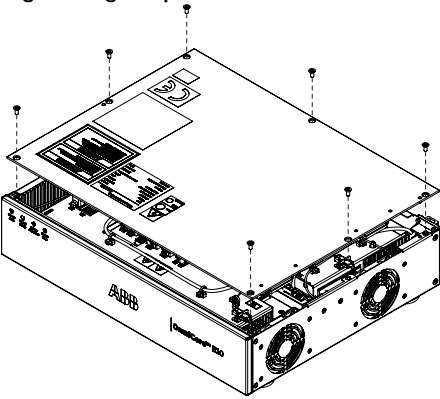
	Action	Info/illustration								
3	Assemble the desktop mounting kit front cover according to the guide pins.	 <p>xx2200000743</p> <table border="1" data-bbox="991 703 1433 913"> <tr> <td data-bbox="991 703 1038 741">A</td> <td data-bbox="1038 703 1433 741">Desktop mounting kit front cover</td> </tr> <tr> <td data-bbox="991 741 1038 824">B</td> <td data-bbox="1038 741 1433 824">Torx pan head screw M4x8 (3 pcs) Tightening torque: 1.7 Nm±10%</td> </tr> <tr> <td data-bbox="991 824 1038 869">C</td> <td data-bbox="1038 824 1433 869">Guide pin (2 pcs)</td> </tr> <tr> <td data-bbox="991 869 1038 913">D</td> <td data-bbox="1038 869 1433 913">X111 connector</td> </tr> </table>	A	Desktop mounting kit front cover	B	Torx pan head screw M4x8 (3 pcs) Tightening torque: 1.7 Nm±10%	C	Guide pin (2 pcs)	D	X111 connector
A	Desktop mounting kit front cover									
B	Torx pan head screw M4x8 (3 pcs) Tightening torque: 1.7 Nm±10%									
C	Guide pin (2 pcs)									
D	X111 connector									
4	Secure with the screws.									
5	Assemble the Harness ID LED status through the hole. <ul style="list-style-type: none"> A2.X14-X111 	 <p>xx2200000744</p>								
6	Refit the top cover and secure with screws.	<p>Screws: Torx, countersunk screw M4x10 (7 pcs) Tightening torque: 1.7 Nm±10%.</p>  <p>xx2200000745</p>								
7	Place the controller in desired place.									

3 Installation and commissioning

3.4.4 Mounting the FlexPendant holder

3.4.4 Mounting the FlexPendant holder



Note

To avoid dropping the FlexPendant from height, the holder should be placed in a comfortable working height.

Always use and store the FlexPendant in such a way that the cable does not become a tripping hazard.

When not using the device, place it so it does not accidentally fall.

Required equipment

Equipment	Spare part number	Note
Standard toolkit		See Standard toolkit for controller on page 212 .
FlexPendant Holder w/t E-stop cover	3HAC064927-001	



Note

The FlexPendant should always be placed in the holder when it is not used and it is not allowed to use by unauthorized person.

Continues on next page

Mounting the bracket for the emergency stop on the FlexPendant holder

The FlexPendant holder is shipped without the bracket for the emergency stop assembled to the holder. They are separated as two parts.

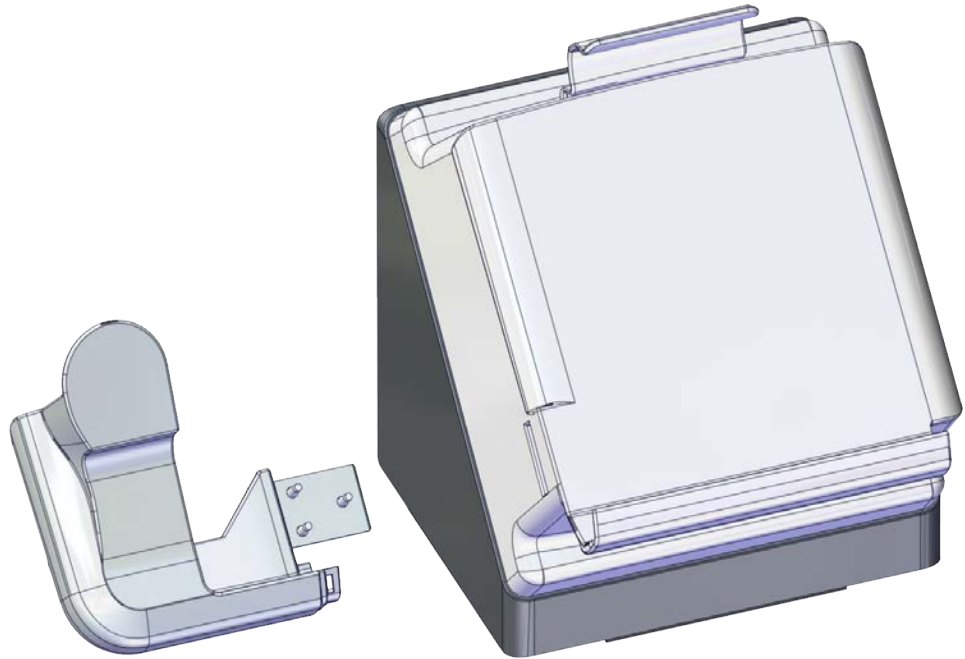

xx210000767

Use this procedure to mount the bracket for the emergency stop to the FlexPendant holder.



	Action	Note/illustration
1	Remove the four screws.	 <p>xx2000002356</p>
2	Separate the rear part from the FlexPendant holder.	

Continues on next page

3 Installation and commissioning

3.4.4 Mounting the FlexPendant holder

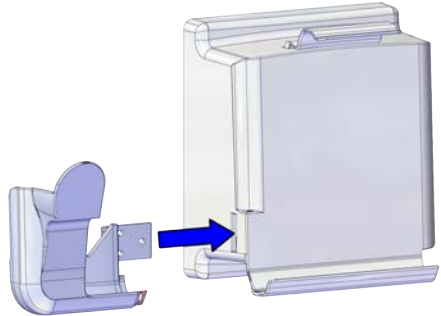

Continued

	Action	Note/illustration
3	Insert the bracket into the FlexPendant holder.	 <p>xx2100000765</p>
4	Secure with the screws.	<p>Screws: BN33 Phillips pan head tapping screw ST2.9x13 (3 pcs) Tightening torque: 6 Nm-7.8 Nm</p>  <p>xx2100000766</p>
5	Refit the rear part and secure with the screws.	<p>Screws: BN33 Phillips pan head tapping screw ST3.5x16 (4 pcs) Tightening torque: 9.4 Nm-12.2 Nm</p>  <p>xx2000002356</p>

Continues on next page

Mounting the FlexPendant holder onto a flat surface (Horizontally)

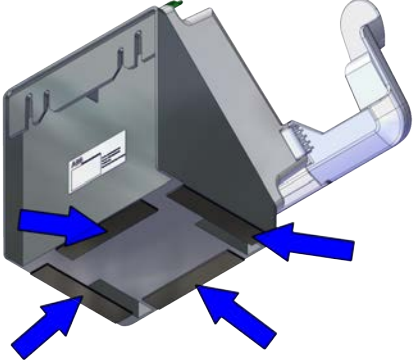
Use this procedure to mount the FlexPendant holder onto a flat surface, like the top of the controller or a desktop.

	Action	Note/illustration
1	Clean the surface and make sure it is dry.	
2	Remove the protective liner from the tape.	 <p>xx2000002352</p>
3	Press the holder onto the desired place.	 <p>xx2000002353</p>

Hanging the FlexPendant holder with the bracket

Use this procedure to hang the FlexPendant holder on any place that can hold the bracket, like the door of the equipment.



Tip

The bracket is included on delivery.

Continues on next page

3 Installation and commissioning

3.4.4 Mounting the FlexPendant holder

Continued

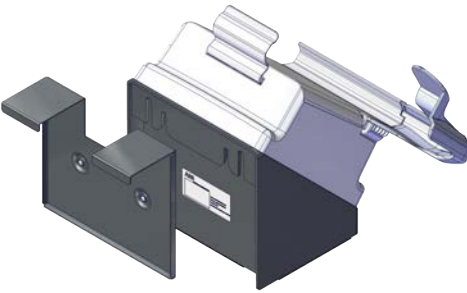
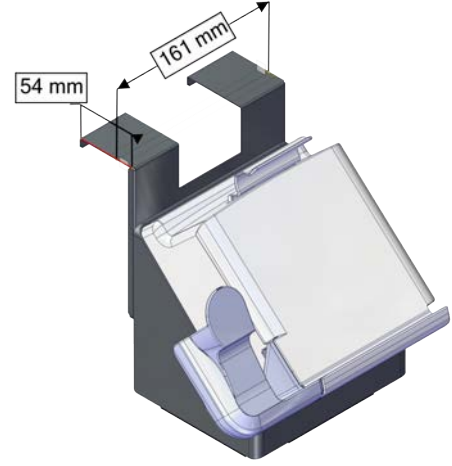
	Action	Note/illustration
1	Hang the FlexPendant holder to the bracket according to the screws on the bracket.	 <p data-bbox="925 674 1034 694">xx2000002354</p>
2	Hang the holder with the bracket to the desired place.	 <p data-bbox="925 1200 1034 1220">xx2000002355</p>

Hanging the front part of the FlexPendant holder with screws (Vertically)

Use this procedure to hang the front part of the FlexPendant holder to the desired place.

	Action	Note/illustration
1	Remove the four screws.	 <p data-bbox="925 1928 1034 1948">xx2000002356</p>
2	Separate the rear part from the FlexPendant holder.	
3	Clean the surface and make sure it is dry.	

Continues on next page

3 Installation and commissioning

3.4.4 Mounting the FlexPendant holder

Continued

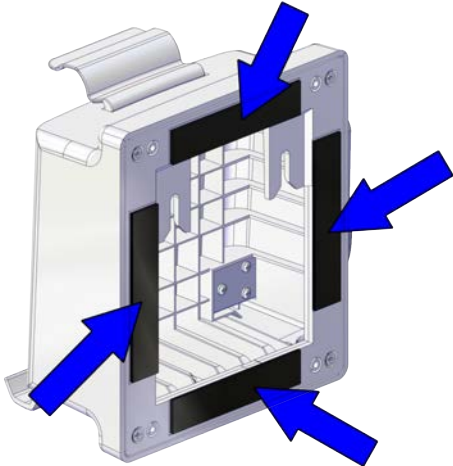
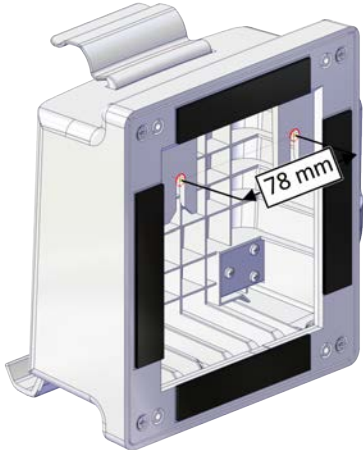
	Action	Note/illustration
4	Remove the protective liner from the tape.	 <p>xx2000002357</p>
5	Press the holder onto the desired place.	
6	Use two M5 screws to secure the holder.	 <p>xx2000002358</p>

3 Installation and commissioning

3.4.5 Changing the fan control functionality

3.4.5 Changing the fan control functionality

General

The cooling fan on OmniCore E10 controller will work on reduced speed or shut off while the controller is in motors off state to lower the sound level. This is called fan control functionality.

The fan will run with full cooling capacity when the controller is in motors on state. When changing to motors off, the fan will shut off if the temperature on the incoming air is low enough, or run in reduced speed if the temperature is too high.

When the controller state is changed to motors off, the fan will shut off after 60 seconds if the temperature on the incoming air is low enough. If the temperature is too high, then the fan will continue at reduced capacity until the temperature is low enough and then turn off the fan.

Changing the fan control functionality

Use this procedure to change the fan control functionality.

	Action	Note
1	Open the configuration editor in RobotStudio.	
2	In the topic Controller , navigate to the type Fan Control .	
3	Set the parameter <i>Turn off fan</i> to <i>NO</i> if the fan should not shut off in motors off state. The default setting is <i>YES</i> .	For more information about system parameters, see <i>Technical reference manual - System parameters</i>

3.5 Electrical connections

3.5.1 Connectors on the OmniCore E10 controller

General

The following section describes the connectors on the front panel of the OmniCore E10 controller.



CAUTION

Always inspect connectors for dirt or damage before connecting them to the controller. Clean or replace any damaged parts.

Connectors

The following illustration shows the connection interface on the controller.

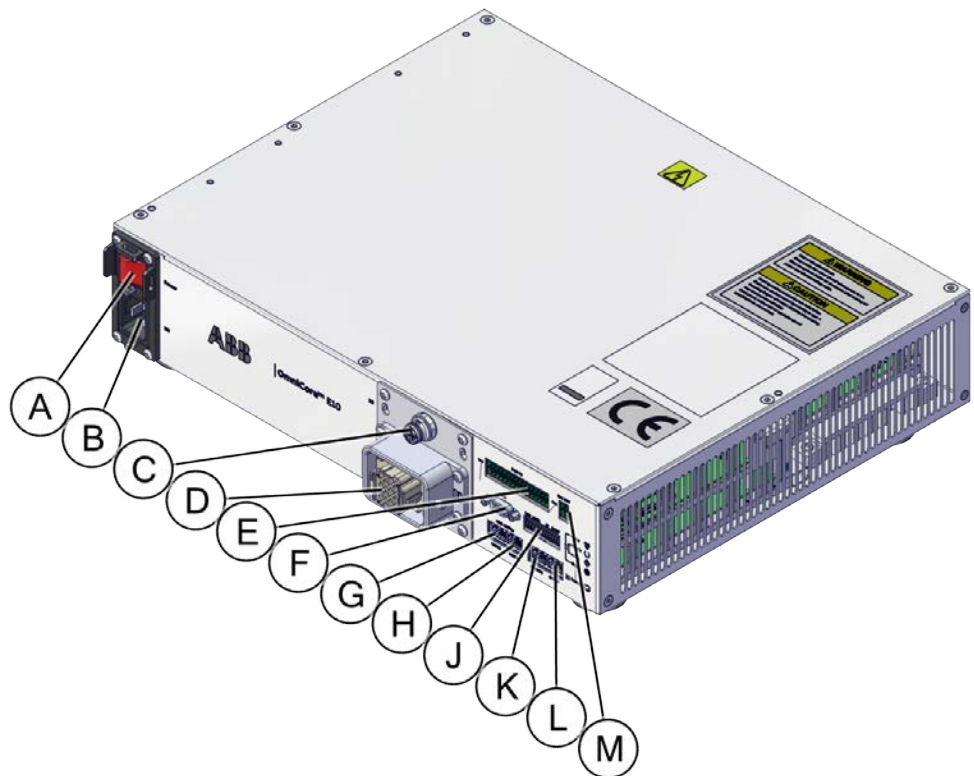

xx2100001299

	Description	Label	Reference on the circuit diagram
A	Power inlet switch	Power	Q0
B	Power inlet connector	X0	X0
C	Manipulator signal connector (SMB)	X2	X2
D	Motor connector	X1	X1

Continues on next page

3 Installation and commissioning

3.5.1 Connectors on the OmniCore E10 controller

Continued

	Description	Label	Reference on the circuit diagram
E	I/O interface	X5	A2.X6
F	FlexPendant adaptor connector (HMI)	HMI	A2.X8
G	WAN1 port	WAN1	A2.X1
H	WAN2 port	WAN2	A2.X2
J	Customer safety interface	MON, AS/GS, ES, ESOUT	A2.X5
K	Device port	DEVICE	A2.X3
L	Management port	MGMT	A2.X4
M	External 24 V power inlet connector	X6	A2.X7

Power inlet switch

Use the power inlet switch to turn on and off power to the controller. It is also possible to restart the controller using the FlexPendant.



Note

When restarting the controller, wait until the computer and logic unit status LED Computer has turned off before turning on power again.

Safety lock for power inlet switch

The following illustration shows the location of the safety lock for the power inlet switch.

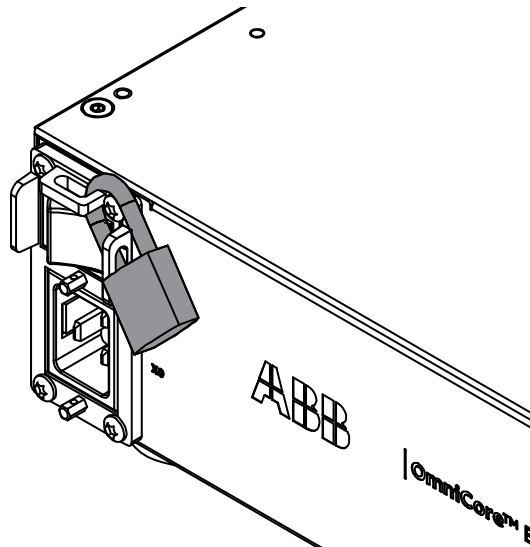

xx2100001300

Continues on next page

3 Installation and commissioning

3.5.1 Connectors on the OmniCore E10 controller

Continued

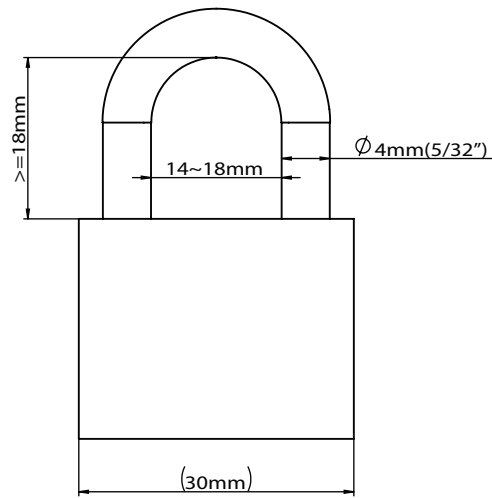

xx2100001310

3 Installation and commissioning

3.5.2 Connecting cables to the controller

3.5.2 Connecting cables to the controller

General

A good and proper electrical installation of the robot system is necessary to ensure the best performance and prolong the lifetime of the whole robot system.

This section includes important information on how to connect cables and signals to the controller.

Signal classes

Different rules apply to the different classes when selecting and laying cables. Signals from different classes must not be mixed.

Signal class	Description
Power signals Class 4 (noisy)	Supplies external motors and brakes. Applies to the cables associated with the power inputs and outputs of variable speed drives. Cables carrying strongly interfering signals such as motor cables, DC-link load sharing, unsuppressed inductive loads, DC motors, welding equipment, etc.
Control signals Class 3 (slightly noisy)	Digital operating and data signals (digital I/O, protective stop, etc.). Applies to cables carrying slightly interfering signals: AC power supply (<1 kV), DC power (24 V), power to equipment with RFI/EMI filters, control circuits with resistive or suppressed inductive loads (such as contactors and solenoids), direct-on-line induction motors, etc.
Measurement signals Class 2 (slightly sensitive)	Analog measurement and control signals (resolver and analog I/O). This class covers ordinary analogue signals such as analogue signals (4-20 mA, 0-10V, or signals below 1 MHz), low-speed digital signals (RS232, RS485), digital (on/off) signals, limit switches, encoders, etc.
Data communication signals Class 1 (sensitive)	Gateway (fieldbus) connection, computer link. Applies to cables carrying very sensitive signals. Signals with a full-scale range less than 1 V or 1 mA, and/or a source impedance >1 kOhm, and/or a signal frequency >1 Mhz. For example high-speed digital communication (Ethernet), thermocouples, thermistors, strain gauges and flowmeters.

Selecting cables

All cables laid in the control cabinet must be capable of withstanding 70 °C. In addition, the following rules apply to the cables of certain signal classes:

Signal class	Cable type
Power signals	Shielded cable with an area of at least 0.75 mm ² or AWG 18.
Control signals	Shielded cable.
Measurement signals	Shielded cable with twisted pair conductors.
Data communication signals	Shielded cable with twisted pair conductors. A specific cable should be used for field bus connections and Ethernet, according to the standard specification of the respective bus.

Continues on next page



Note

Any local standards and regulations concerning insulation and area must always be complied with.

AC current in CP/CS

For specific applications where the correct cable dimensioning can depend on the relationship between the period of the duty cycle and the thermal time constant of the cable (for example, starting against high-inertia load, intermittent duty), the cable manufacturer can provide information.

Country specific norms have to be included.

The wire is not dimensioned to take care of starting motors or transformers.

The following table shows how much AC current can be supplied with a specific temperature, and the wire size.

Wire size (mm ² //AWG)	AC current			
	40°C//104F	45°C//113F	50°C//122F	52°C//125.6F
Single wire 0.2//24	4.5	4.1	3.7	3.2
Multi wire 2 pair 0.2//24	3.6	3.3	3.0	2.6
Multi wire 4 pair 0.2//24	2.9	2.7	2.4	2.1
Multi wire 6 pair 0.2//24	2.6	2.3	2.1	1.8
Multi wire 9 pair 0.2//24	2.3	2.0	1.8	1.6
Single wire 0.5//20	7.9	7.2	6.5	5.6
Multi wire 2 pair 0.5//20	6.3	5.8	5.2	4.5
Multi wire 4 pair 0.5//20	5.1	4.7	4.2	3.6
Multi wire 6 pair 0.5//20	4.5	4.1	3.7	3.2
Multi wire 9 pair 0.5//20	4.0	3.6	3.2	2.8
Single wire 0.75//18	9.5	8.6	7.8	6.7
Multi wire 2 pair 0.75//18	7.6	6.9	6.2	5.4
Multi wire 4 pair 0.75//18	6.2	5.6	5.1	4.4
Multi wire 6 pair 0.75//18	5.4	4.9	4.4	3.8
Multi wire 9 pair 0.75//18	4.8	4.3	3.9	3.4
Single wire 1.0//17	11.0	10.0	9.0	7.8
Multi wire 2 pair 1.0//17	8.8	8.0	7.2	6.2
Multi wire 4 pair 1.0//17	7.2	6.5	5.9	5.1
Multi wire 6 pair 1.0//17	6.3	5.7	5.1	4.5
Multi wire 9 pair 1.0//17	5.5	5.0	4.5	3.9
0.75//18 three phase	8.6	7.8	7.1	5.6
1.0//17 three phase	10.3	9.4	8.4	6.7

Continues on next page

3 Installation and commissioning

3.5.2 Connecting cables to the controller

Continued

Route the cables

Routing of cables shall be done in a professional way.

- Cables of different classes, such as signal cables and power cables, must not be routed together as the power cables may introduce noise in the signal cables. The greater the separation distance, the lesser the risk for interference between the cables.
- Robot controller mains supply input cable and robot power cable should be separated even though they belong to the same class.
- If crossing cables from different classes, cables should cross at an angle close to 90 degrees.
- All external cables that are to be connected inside the controller must be shielded in the chassis before entering the cabinet.

Separation distances can be reduced if e.g. dividers are used between cables classes. Manufacturers of cable duct systems can provide information on how reduced separation distances can be achieved using their specific products.

Signal class	Cable type
Power signals	<ul style="list-style-type: none">• These signals generate a lot of interference and must be laid separate from control, measurement, and communication signals.• The shielding must be connected to a paint-free part of the panel chassis of the cabinet at both ends of the cable. Any unshielded cable must be as short as possible.• The manipulator power cables are routed on the floor and along the left side of the controller cabinet.• Cables should not be wound up like coils. This could cause an magnetic field disturbing the signals. There will also be a risk of overheating depending on the load.
Control signals	<ul style="list-style-type: none">• These signals are very sensitive to interference. To protect these signals they should not be laid along with the power signals.
Measurement signals	
Data communication signals	

Shielding cables

When peripheral devices are connected to the robot system, a shielded cable is necessary to reduce coupling of the inner cable conductors to the environment they pass through.

Shielding cable requirements

- The best method for shielding is to ground the shield at both ends of the cable, provided the ends grounding are at the same potential.
- If the grounding points have different electric potentials - grounding both ends will create a ground loop allowing unwanted current to flow in the shield. In such cases one end grounding may be used. The grounding point should then be at the robot controller side.
- Cables carrying analog low-level signals is another exception where the shield should be grounded at only one end.

Continues on next page

- Most data network and field bus types have defined grounding topologies. If such grounding schemes exist, they should be followed.
- In complex interference environments, two-layer shielding may be required. The inner shield should be grounded at the controller side only end and the outer shield should be grounded at both ends. The optimum shielding is a combination of foil and braid screens.
- The best connection is one in which the shielding is extended up to and makes a solid 360° connection (shown below) with the ground plane or chassis.

Shielding example

The below example shows the shielding of a d-type connector:

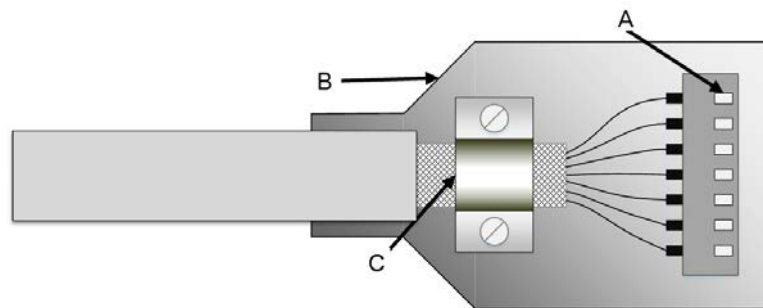

xx1700001320

- A A dimpled connector body makes multiple bonds to the mating connector body all around its periphery, 360° bonding.
- B Metal, or metallized, back shell makes 360° bond to the connector body.
- C The cable shield is exposed and 360° clamped to the back shell. A tight fit is a must.

Many other 360° bonding methods and types of 360° shielded connectors are also acceptable.

Shield pigtail termination

Shield pigtail termination, as shown below, shall be avoided. If a pigtail connection cannot be avoided, make it as short as possible.

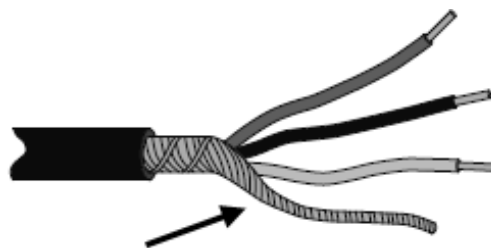

xx1700001321

Continues on next page

3 Installation and commissioning

3.5.2 Connecting cables to the controller

Continued

Ground and screen connections

The task of the grounding system is twofold - protective and functional. The primary task is to serve as protective earth (PE) for personal and equipment safety. The secondary task is to serve as a return path for common mode current.

For further information refer to EN 60204-1 and UL 1740.

Grounding requirements

The controller cabinet ground must come from the mains power supply PE.

- The grounding cable color shall be green-yellow.
- The ground for the controller cabinet, robot manipulator and peripheral devices must be the same, preferably an equipotential ground grid (mesh).
- Ground connection points must have stable inter-metallic bonding, like screw fixation. Paint, dirt, rust, and other insulating material must be removed from the contacting surfaces.

For requirements on the marking of the supply ground connection inside the control cabinet refer to UL 508C. For further details on how grounding systems should be designed refer to IEC 61000-5-2. For details of cross-sectional area of PE refer to IEC 60204-1.

Grounding installation

For information on how to connect protective earth to the OmniCore controller cabinet, see [Connecting incoming mains and protective earth to the controller on page 79](#).

For information on how to connect protective earth for the manipulator, see the corresponding product manual.

Continues on next page

Examples

The following figure shows 2 examples on how protective earth and the signal cable screens can be connected:

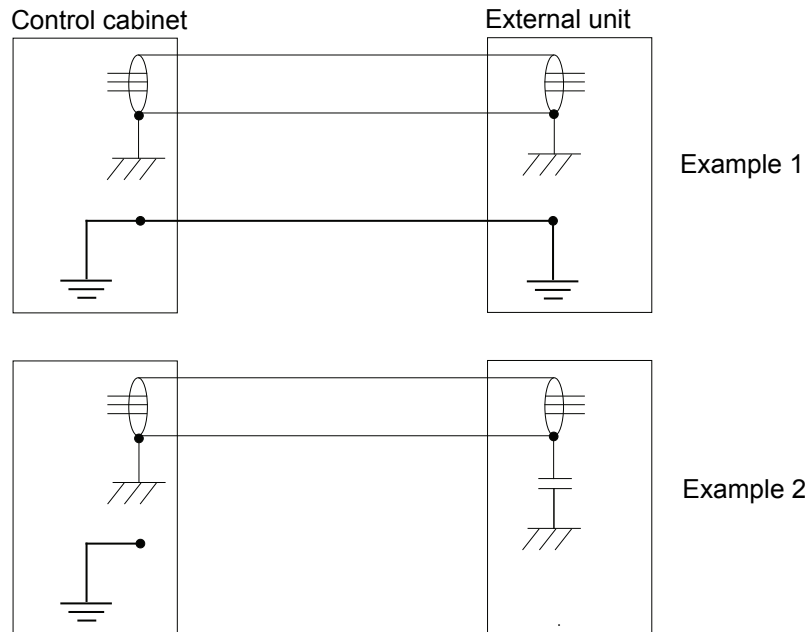

xx120000960

Example 1:

- Where a good earth connection is available on all units, the best shielding is obtained by grounding all screens at both ends on all units.

Example 2:

- If the cable is terminated where a good earth connection is not available a noise suppression capacitor can be used. The screens of the 2 cables must be connected as shown in the figure, but not connected to the chassis of the unit.

Continues on next page

3 Installation and commissioning

3.5.2 Connecting cables to the controller

Continued

Interference elimination

Internal relay coils and other units that can generate interference inside the control cabinet are neutralized. External relay coils, solenoids and other units must be clamped in a similar way. The illustration below shows how this can be done.

Note that the turn-off time for DC relays increases after neutralization, especially if a diode is connected across the coil. Varistors give shorter turn-off times. Neutralizing the coils lengthens the life of the switches that control them.

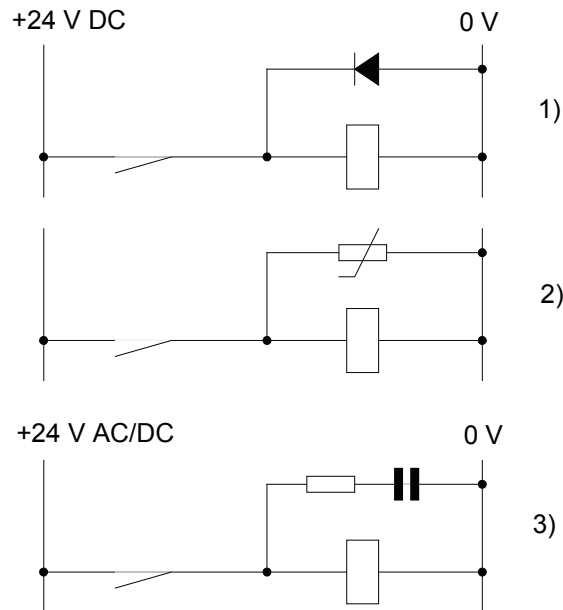

xx1200000961

- 1 The diode should be dimensioned for the same current as the relay coil, and a voltage of twice the supply voltage.
- 2 The varistor should be dimensioned for the same energy as the relay coil, and a voltage of twice the supply voltage.
- 3 When AC voltage is used, the components needs to be dimensioned for >500 V max voltage and 125 V nominal voltage.

The resistor should be 100 Ω , and the capacitor should be 1W 0.1 - 1 μF (typically 0.47 μF).

3.5.3 Connecting the manipulator to the controller

General

Connect the manipulator and the controller to each other after installing them. The lists below specify which cables to be used in each application.

All connectors on the controller are shown in section [Connectors on the OmniCore E10 controller on page 67](#).



CAUTION

Verify that the serial number is according to the number(s) in the *Declaration of Incorporation (DoI)*.

Main cable categories

All cables between the manipulator and the controller are divided into the following categories:

Cable category	Description
Manipulator cable	Handles power supply to and control of the manipulator's motors as well as feedback from the serial measurement board.
Position switch cables (option)	Handles supply to and feedback from any position switches.
Customer cables (option)	Handles communication with equipment fitted on the manipulator by the customer.
Additional axes cables (option)	Handles power supply to and control of the external axes motors as well as feedback from the servo system.

These categories above are divided into sub-categories which are specified in spare part manual. See [Manipulator cables on page 232](#).

Connecting the cables from the manipulator to the controller

	Action
1	Connect the manipulator cable to the connector X1.
2	Lock the connector with the lever.
3	Secure the cables to avoid tripping or wear.

3 Installation and commissioning

3.5.4 Fitting the connector for incoming mains

3.5.4 Fitting the connector for incoming mains

General

This section describes how to manufacture a cable for connecting the main power to the controller.

Detailed view

Connector	Connector article number	Description
Connector AC power inlet	3HAC077706-001	IEC 60320 C19 connector As this is a standard connector, it is suggested to use the normal method to fit the connector.

Specifications

The following describes the cable requirements for the incoming mains connection to the OmniCore E10 controller.

Component	Description
Cable type	Flexible oil resistant rubber
Cable area	3C x 1.5 mm ² or AWG16
Protective earth	PE1 and PE2 points on X0 (incoming mains connector).

3.5.5 Connecting incoming mains and protective earth to the controller

Introduction



Note

How to manufacture a cable with connector is described in section [Fitting the connector for incoming mains on page 78](#).



DANGER

A residual current device (RCD) must be installed. See [Residual current on page 41](#).

Prerequisites

Before incoming mains is connected to the controller, the following prerequisites must be fulfilled:

- An external circuit breaker or fuse must be installed. See [Line fusing on page 80](#).
- The cabinet must be connected to protective earth. See [Connection of protective earth on page 80](#).
- A residual current device (RCD) must be installed. See [Residual current on page 41](#).

Location of incoming mains connection



xx2100001301

Continues on next page

3 Installation and commissioning

3.5.5 Connecting incoming mains and protective earth to the controller

Continued

Connection of protective earth

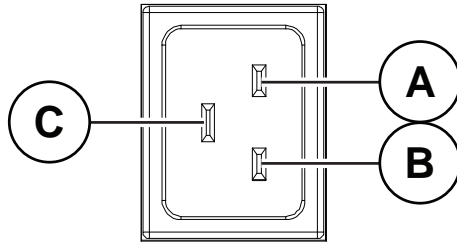

xx2100001302

	Description
A	Live (L1)
B	Neutral (N) or Live (L2)
C	Protective Earth (PE), grounding

Required equipment

Equipment	Note
External earth fault protection (residual current device, RCD)	30, Type B (ABB F202 B-16/0.03 or equal residual current circuit breaker.)
Standard toolkit	See Standard toolkit for controller on page 212 .
Circuit diagram	<i>Circuit diagram - OmniCore E10, 3HAC076810-008</i>

Connecting the power

The following procedure describes how to connect the main power to the controller.



CAUTION

Always inspect the connector for dirt or damage before connecting it to the controller. Clean or replace any damaged parts.

	Action	
1	Connect the main power cable to the incoming mains connector X0 and lock it by pressing the locking levers.  Tip When you hear a clear clicking sound, it is locked.	

Line fusing

There is no integrated fuse inside OmniCore E10 controller. An external fuse or circuit breaker must be added by the integrator, according to the full load current rating. The full load current for the robot is marked on the controller name plate, and is also displayed in section [Line fusing on page 40](#).

3.5.6 Detaching and attaching a FlexPendant

Introduction

With the option *Hot swappable FlexPendant [3018-1]* it is possible to detach and attach the FlexPendant from an OmniCore controller in automatic mode, without interrupting the ongoing process.

Detaching the FlexPendant in manual mode will always result in an emergency stop.



Note

Detaching the FlexPendant is possible only if the logged in user has the **Detach the FlexPendant** grant.



CAUTION

Before detaching the FlexPendant, another emergency stop shall be available.



CAUTION

With a detached FlexPendant, there is no visual identification of the operating mode.



CAUTION

A FlexPendant that is not connected to the robot must be stored out of sight so that it cannot be mistaken for being in use.



CAUTION

The FlexPendant connector shall only be used to connect the FlexPendant.
All external safety devices must be connected from the customer safety interface.

Continues on next page

3 Installation and commissioning

3.5.6 Detaching and attaching a FlexPendant

Continued

Location of FlexPendant connector

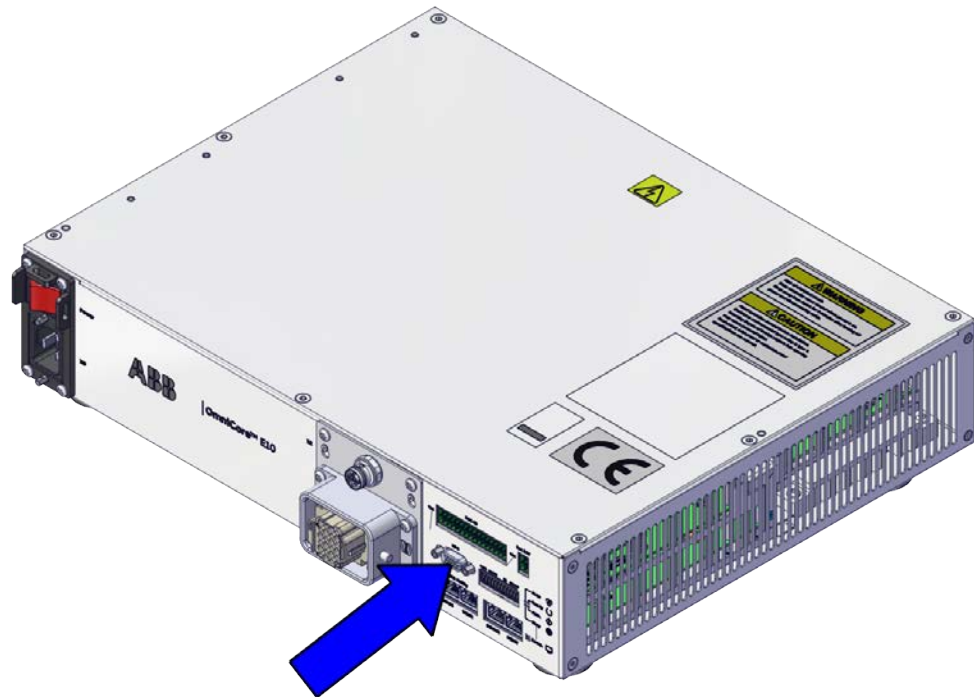

xx2100001304

Detaching the FlexPendant in automatic mode

Use the following procedure to detach the FlexPendant in automatic mode:

- 1 On the status bar, tap the **QuickSet** button.
- 2 Tap the **Logout/Restart** tab.
- 3 In the **FlexPendant** section, tap **Detach FlexPendant**.

Continues on next page

The Detach FlexPendant window is displayed.

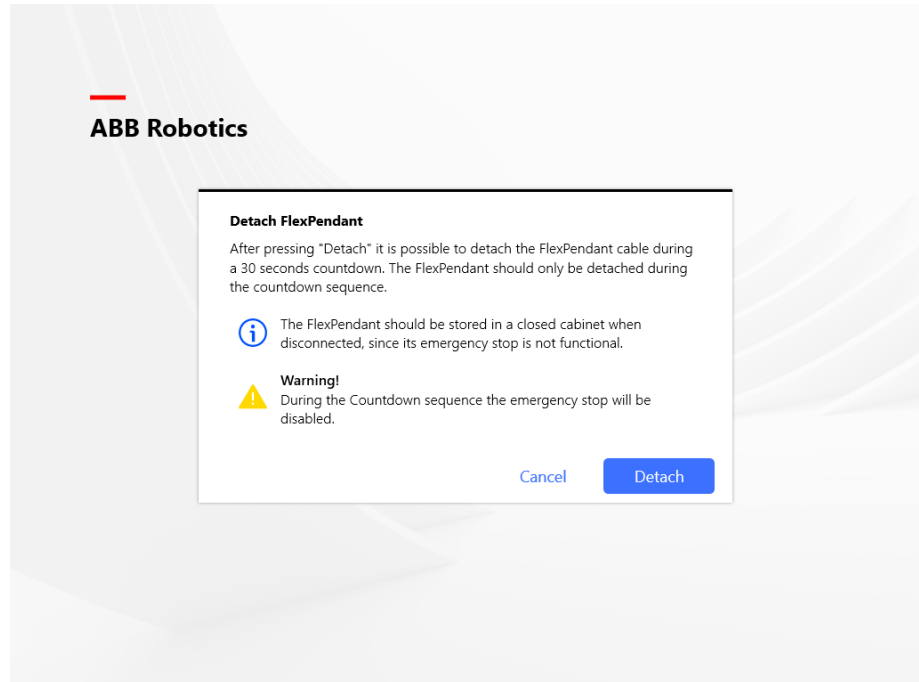

xx1900000403

4 Tap Detach.

A popup window with 30 seconds countdown timer is displayed.

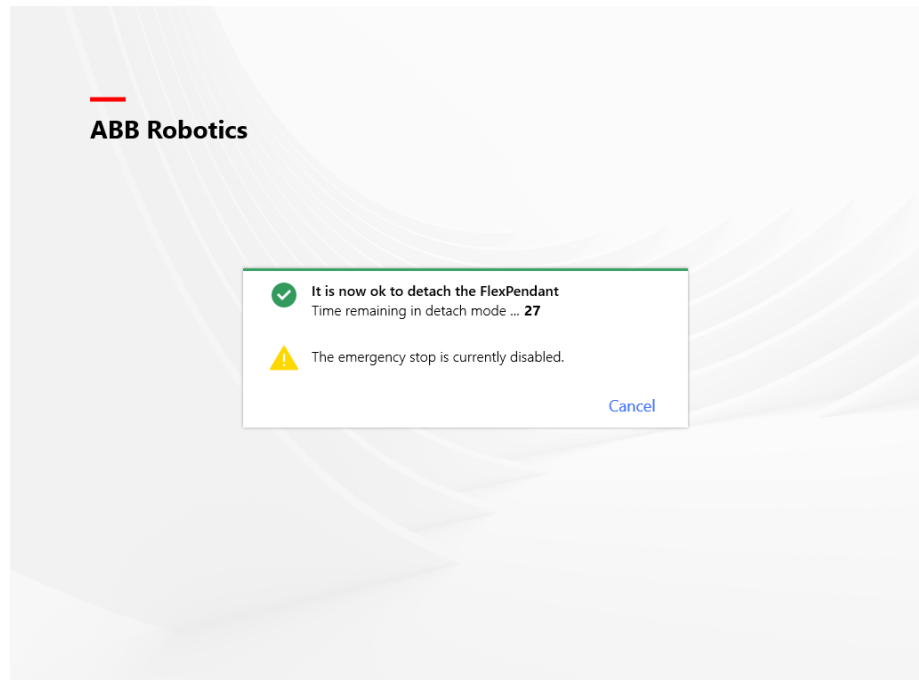

xx1900000404

5 When the countdown is progressing, detach the FlexPendant.

Continues on next page

3 Installation and commissioning

3.5.6 Detaching and attaching a FlexPendant

Continued

When detached, the FlexPendant will shut down.



Note

If the FlexPendant is not detached within 30 seconds, the process for detach of the FlexPendant is aborted.



WARNING

If the FlexPendant is detached after the 30 seconds countdown has passed, the controller will enter emergency stop state.

Attaching the FlexPendant



CAUTION

Always inspect the connector for dirt or damage before attaching. Clean or replace any damaged parts.

Attach the connector to the controller and tighten the locking ring or screws.



Note

The OmniCore E10 controller has an adapter cable in between the controller and the FlexPendant.

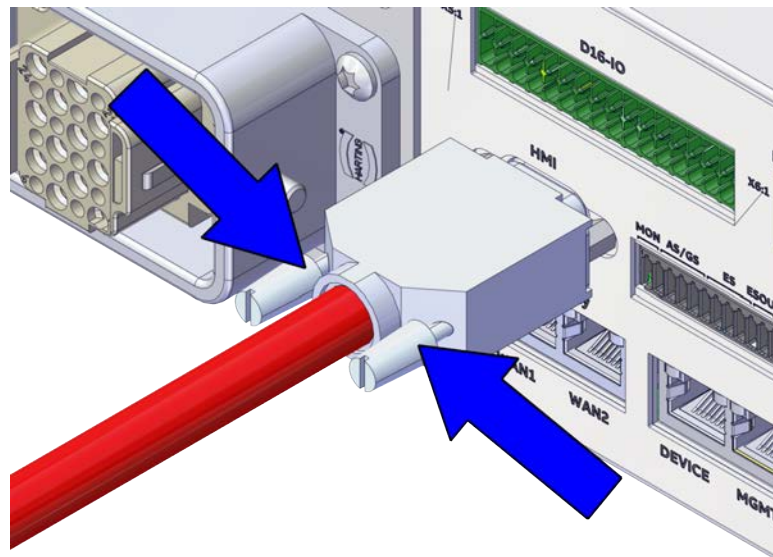

xx2100001343



CAUTION

Make sure that the emergency stop device is not pressed in before attaching the FlexPendant.

3.5.7 Ethernet networks on OmniCore

Network segment overview

The Ethernet networks used by OmniCore are distributed into the following segments:

Network segment	Controller ports	Usage
Private Network	DEVICE	Process equipment local to this specific robot.
	MGMT (Management)	ABB service personnel.
	HMI (FlexPendant)	FlexPendant connection.
Ability Network	WAN 2	ABB Ability™ connection.
Public Network	WAN 1	Public/factory network.

Connectors

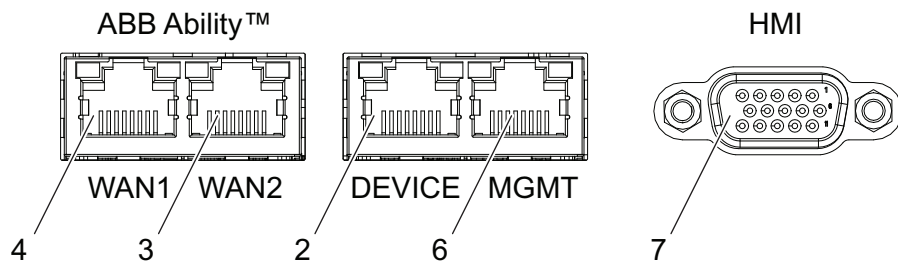

xx2100002083

	E line controller label	Description
2	DEVICE	Connected to the controller's Private Network. Intended for connecting ABB Scalable I/O units and network based process equipment local to the controller.
3	WAN 2	Intended for connecting the controller to internet/ABB Ability™.
4	WAN 1	Connected to the controller's Public Network. Intended for connecting the robot controller to a factory wide industrial network.
6	MGMT (Management)	<p>Connected to the controller's Private Network. The MGMT port shall be used by service personnel in close proximity to the controller, with a single client connected to the controller.</p> <p>Note</p> <p>The management port shall never be used for more than one client at a time. ABB Robotics assumes no responsibility for any errors/hazards that may appear when more than one client is used.</p>

Continues on next page

3 Installation and commissioning

3.5.7 Ethernet networks on OmniCore

Continued

	E line controller label	Description
7	HMI (FlexPendant)	Specific connector for connecting the Flex-Pendant.

3.5.8 Descriptions for connectors

I/O connectors - Scalable I/O (option)

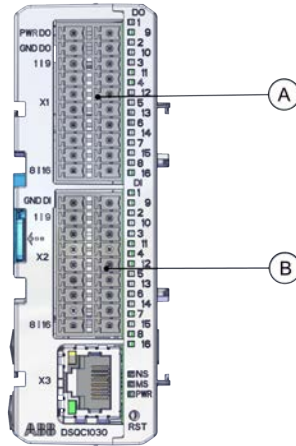

xx1900002448

A	Scalable I/O output connectors
B	Scalable I/O input connectors

The connectors contain 16 digital input signals, 16 digital output signals, 24 V and 0 V for the outputs, and 0 V for the inputs.

For connection details, see *Circuit diagram - OmniCore E10, 3HAC076810-008* and *Application manual - Scalable I/O, 3HAC070208-001*.

Continues on next page

3 Installation and commissioning

3.5.8 Descriptions for connectors

Continued

I/O connectors - X5 - I/O interface

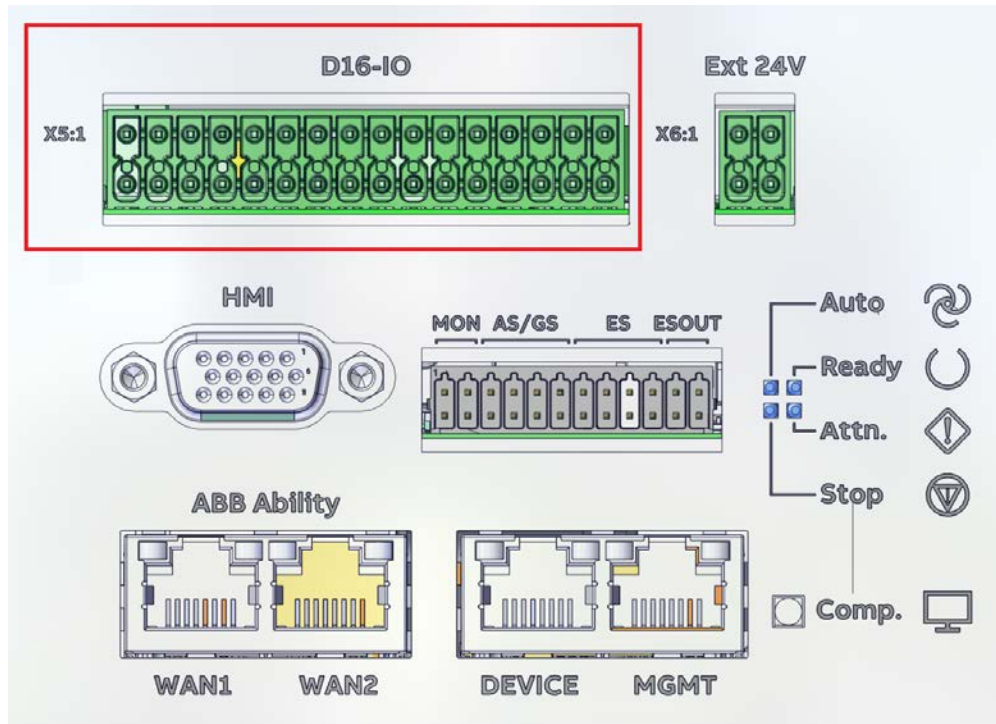

xx2100001306

Continues on next page

3 Installation and commissioning

3.5.8 Descriptions for connectors

Continued

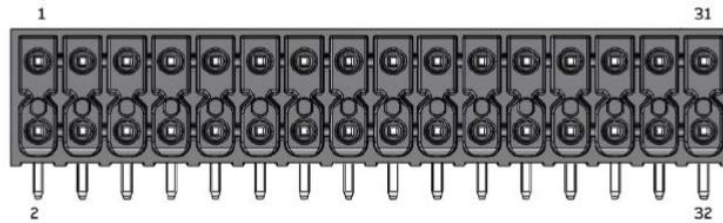

xx2100001309

1	24V_IO_EXT	2	PWR_DO
3	0V_IO_EXT	4	GND_DO
5	DO8	6	DO4
7	DO7	8	DO3
9	DO6	10	DO2
11	DO5	12	DO1
13	0V_IO_EXT	14	0V_IO_EXT
15	GND_DI	16	GND_DI
17	DI16	18	DI1
19	DI15	20	DI2
21	DI14	22	DI3
23	DI13	24	DI4
25	DI12	26	DI5
27	DI11	28	DI6
29	DI10	30	DI7
31	DI9	32	DI8

The connectors contain 16 digital input signals, 8 digital output signals, 24 V and 0 V for the outputs, and 0 V for the inputs.



CAUTION

The process power supply (PWR_DO, GND_DO) should be supplied separately.
The 24V_IO_EXT rails must handle maximum output current of 4 A in total.

For connection details, see *Circuit diagram - OmniCore E10, 3HAC076810-008*.

Customer safety interface - X9



Note

The FlexPendant connector can only be used to connect a FlexPendant and **CANNOT** be used to connect any other devices.

All external safety devices must be connected from the customer safety interface.

Continues on next page

3 Installation and commissioning

3.5.8 Descriptions for connectors

Continued

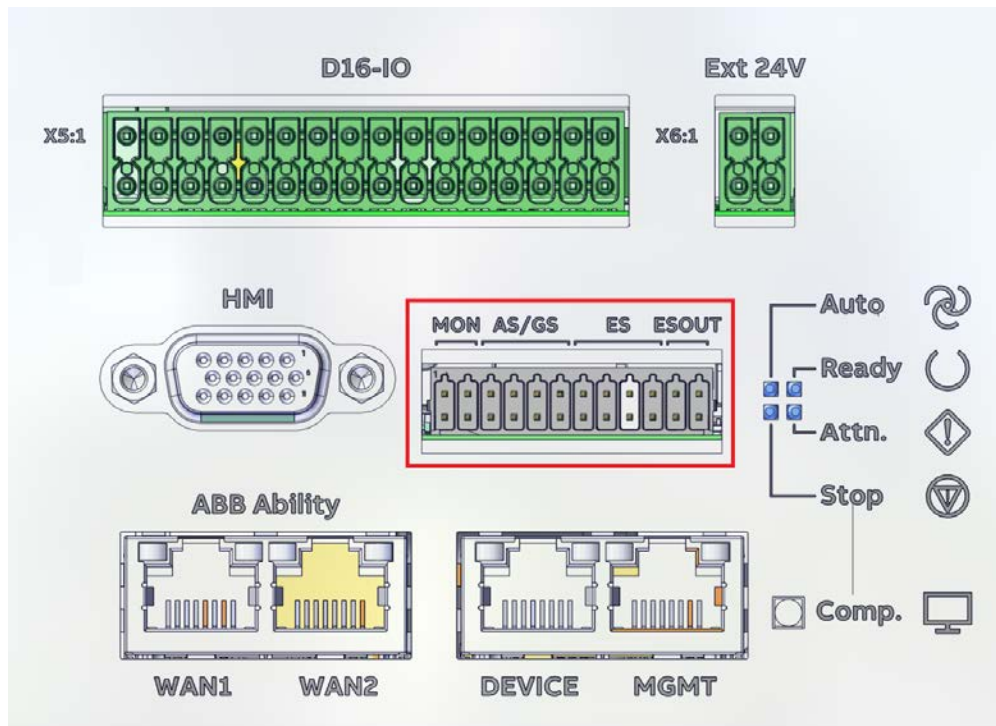

xx2100001307

1	MON_PB	2	24V_MON
3	MON_LAMP	4	24V_MON
5	24V_CH2	6	0V_CH1_CH2
7	AS2/GS2+	8	AS2/GS2-
9	24V_CH1	10	0V_CH1_CH2
11	AS1/GS1+	12	AS1/GS1-
13	24V_CH2	14	0V_CH1_CH2
15	ES2+	16	ES2-
17	24V_CH1	18	0V_CH1_CH2
19	ES1+	20	ES1-
21	ES2_OUT+	22	ES2_OUT-
23	ES1_OUT+	24	ES1_OUT-



CAUTION

Safety functions must be verified before use. Safety functions must be tested regularly.

MON

Pin	Description
MON_PB	Motors on push button input interface.
24V_MON	24 V power supplied by robot controller for motors on lamp and motors on push button use only. It must not be used for any other functions.

Continues on next page

3 Installation and commissioning

3.5.8 Descriptions for connectors Continued

Pin	Description
MON_LAMP	Motors on lamp output interface. The max sink current is 50.

Although the Motors On function is available on the FlexPendant, an interface is provided in this connector for an optional Motors On push button and an indication lamp. Both have 2 pins on the connectors.

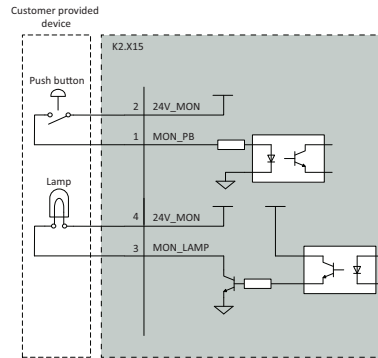

xx1900000598

AS/GS - automatic stop/general stop

Pin	Description
24V_CH1/2	24 V power supplied by robot controller for stop switch use only. It must not be used for any other functions.
AS1/GS1+, AS2/GS2+	Safety loop high side. Customer need to connect these pins to a 24 V power.
AS1/GS1-, AS2/GS2-	Safety loop low side. Customer need to connect these pins to the reference ground of 24 V power.
0V_CH1_CH2	24 V power reference ground.

The controller is shipped with a default configuration that the automatic stop/general stop circuit is opened. The controller CANNOT work.

Continues on next page

3 Installation and commissioning

3.5.8 Descriptions for connectors

Continued

To enable the controller without any additional/external safety equipment, connect the safety circuit as shown in the following figure.

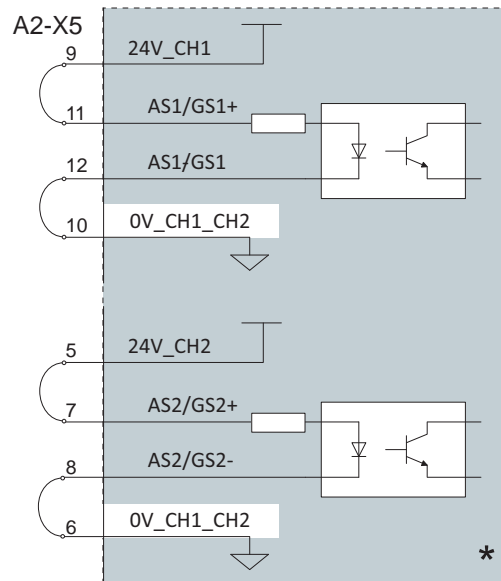

xx2100001568

*: The gray area on the right side of the line represents the inner side of the controller.

In most applications it is required to connect automatic/general stop switches. It is highly recommended to connect the stop switches as one of the following figures

Continues on next page

for the best safety performance. When the 24 V power is provided by customer instead of 24V_CH1/2, it shall be within the tolerance of 24 V -5%/+5%.

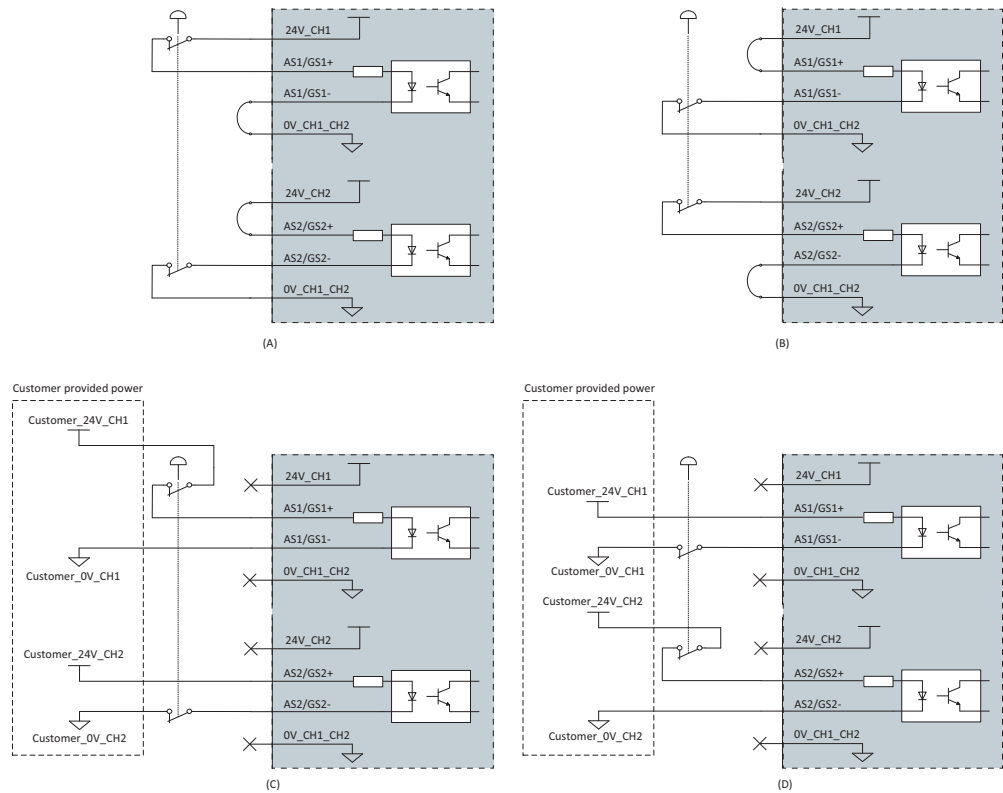

xx2100001570



Note

It is prohibited to connect the dual-channel switch as shown in the following figure, as this does not comply with the Cat.3 structure.

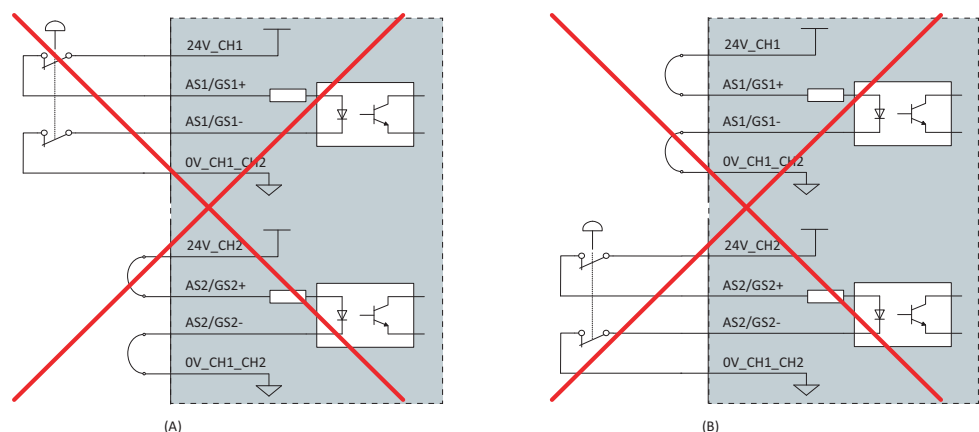

xx2100001571

For more connections other than those illustrated above, carefully assess the risk before use and contact your local ABB for support.

Continues on next page

3 Installation and commissioning

3.5.8 Descriptions for connectors

Continued

ES - external emergency stop



Note

External emergency stop switches are required in below cases in accordance with applicable standards:

- FlexPendant is hot swapped.
- FlexPendant is placed in its holder.

Pin	Description
24V_CH1/2	24 V power supplied by robot controller for stop switch use only. It must not be used for any other functions.
ES1+/ ES2+	Safety loop high side of external emergency stop input.
ES1-/ ES2-	Safety loop low side of external emergency stop input.
0V_CH1_CH2	24 V power reference ground.

The controller is shipped with a default configuration that emergency stop circuit is bypassed (short-circuited).

To enable the controller without any external emergency stop switches, connect the safety circuit as shown in the following figure.

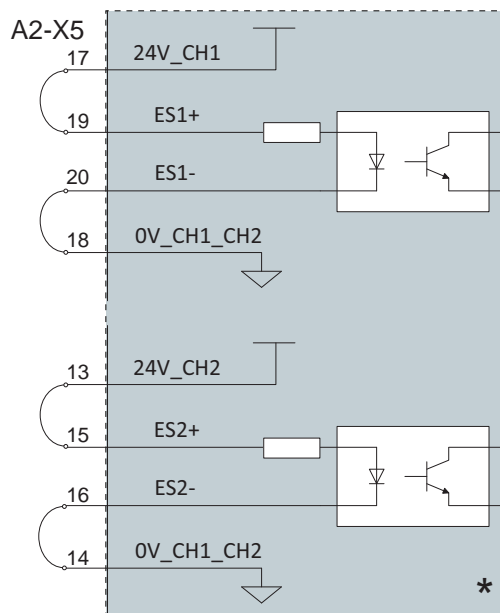

xx2100001569

In most applications it is required to connect external emergency stop switches. It is highly recommended to connect the stop switches as one of the following

Continues on next page

figures for the best safety performance. When the 24 V power is provided by customer instead of 24V_CH1/2, it shall be within the tolerance of 24 V -5%/+5%.

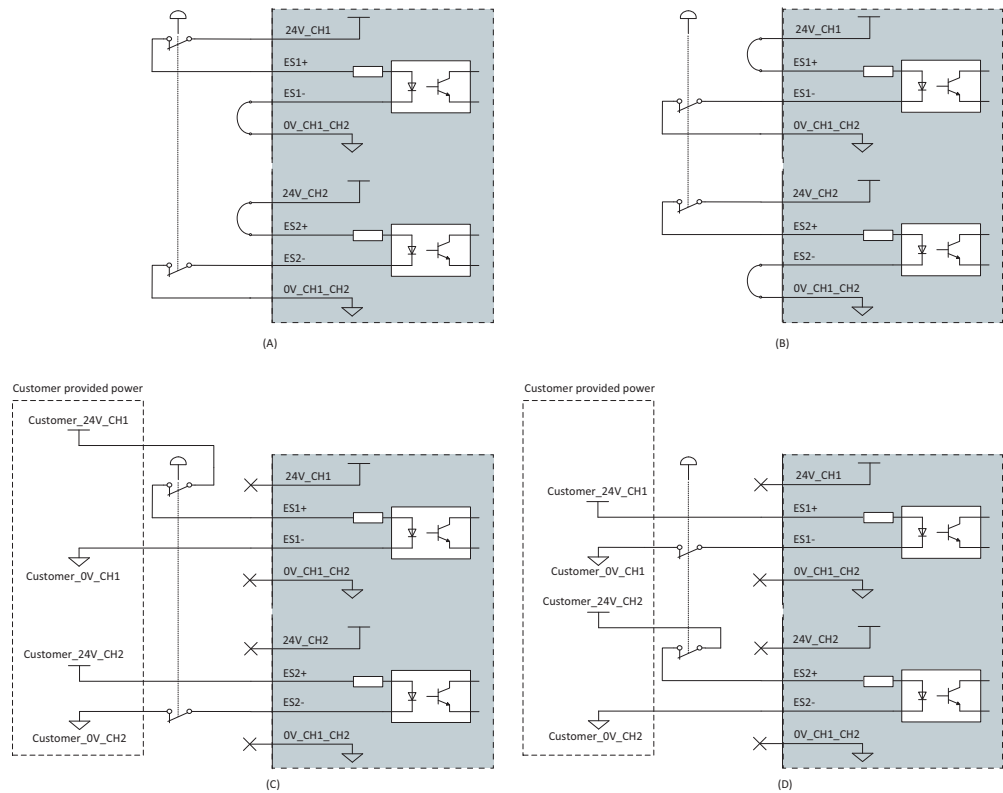

xx2100001572



Note

It is prohibited to connect the dual-channel switch as shown in the following figure, as this does not comply with the Cat.3 structure.

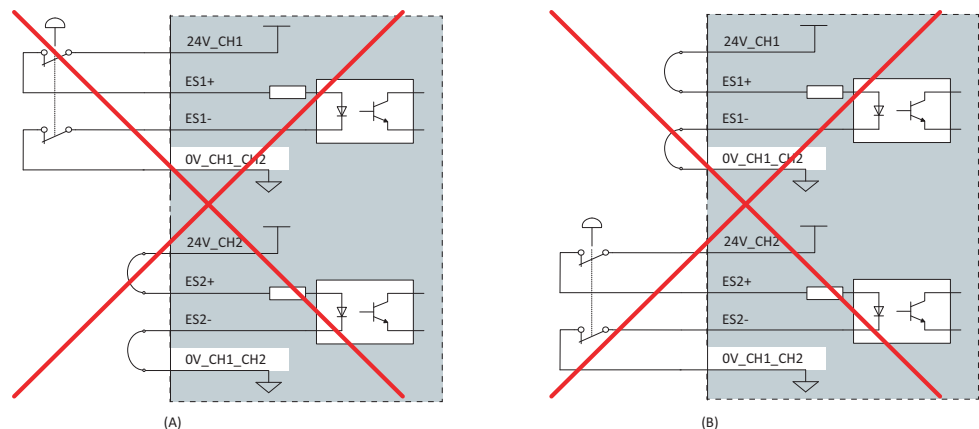

xx2100001573

For more connections other than those illustrated above, carefully assess the risk before use and contact your local ABB for support.

Continues on next page

3 Installation and commissioning

3.5.8 Descriptions for connectors

Continued

ESOUT - emergency stop output

Pin	Description
ESOUT1+	High side terminal of Emergency stop output Channel 1.
ESOUT1-	Low side terminal of Emergency stop output Channel 1.
ESOUT2+	High side terminal of Emergency stop output Channel 2.
ESOUT2-	Low side terminal of Emergency stop output Channel 2.



Note

The ESOUT pins fulfill the IEC 61131-2 Type 0,25 Output.



Note

The device connected to the ESOUT pins shall fulfill the IEC 61131-2 Type 1 Input.

If the device cannot meet the requirement, a safety PLC or relay is needed. ABB Safety Relay E1T 1 s, 24DC is recommended.

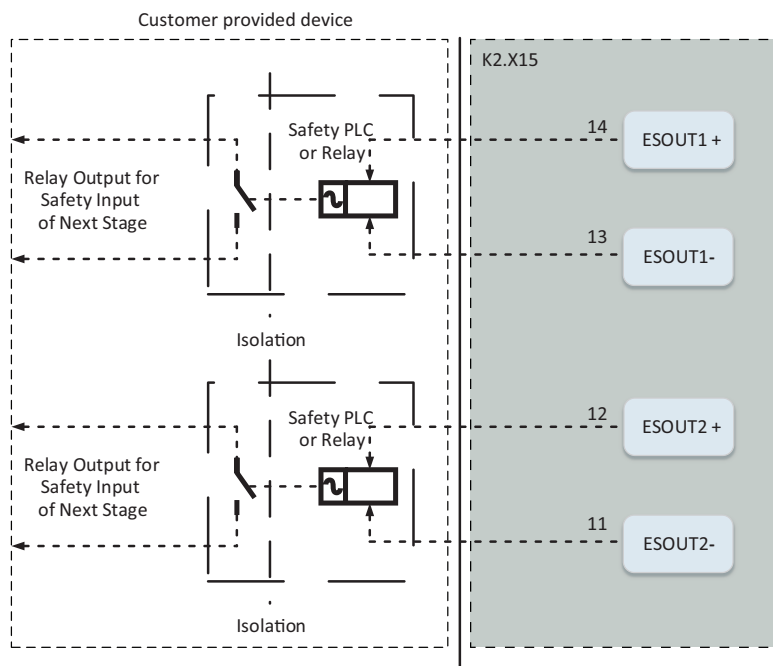

Note

State 0 of Emergency stop output shall be recognized as Emergency stop triggered.



Note

The maximum length of the cable connected to the ESOUT pins shall be 10 m.

Continues on next page



Note

The cable shall be protected from external EM disturbance, suggested to use separate multicore cables.



Note

The ESOUT pins reflect the emergency status of the controller.

ESOUT can be decoupled from ES input to avoid dead-lock in an emergency stop chain, when using RobotWare 7.6 or later. On controllers running RobotWare releases prior to 7.6, it is not recommended to directly connect ESOUT pins to the ES pins on another OmniCore controller. See [Configuring robot stopping functions on page 98](#).

For more connections other than those illustrated above, carefully assess the risk before use and contact your local ABB for support.

Customer optional power input - X6



Tip

This function is reserved for next release.

3 Installation and commissioning

3.5.9 Configuring robot stopping functions

3.5.9 Configuring robot stopping functions

Introduction

The robot stopping functions, protective and emergency stop, are configured using the *Visual SafeMove* functionality in RobotStudio. This includes the emergency stop device on the FlexPendant, and external stop functions.

The protective stop function can be configured to be either an *Automatic Stop (AS)* or a *General Stop (GS)*. When the protective stop function is configured as *General Stop (GS)*, the activation of the protective stop device will initiate the protective stop in any operating mode. When the protective stop function is configured as *Automatic Stop (AS)*, the activation of the protective stop device will initiate the protective stop in automatic mode only.



Note

It is not possible to configure both *Automatic Stop* and *General Stop* at the same time on the OmniCore E10.

For more information about safety configurations, see *Application manual - Functional safety and SafeMove*.

Configure the robot stopping functions in Visual SafeMove



WARNING

The new settings must be verified by test before the robot is used.



Note

Depending on the controller variant and RobotWare version, the configuration options are different.

Not all configurations can be modified.

Use this procedure to configure the robot stopping functions in Visual SafeMove.

- 1 In *Visual SafeMove*, select **Stop Configuration**.

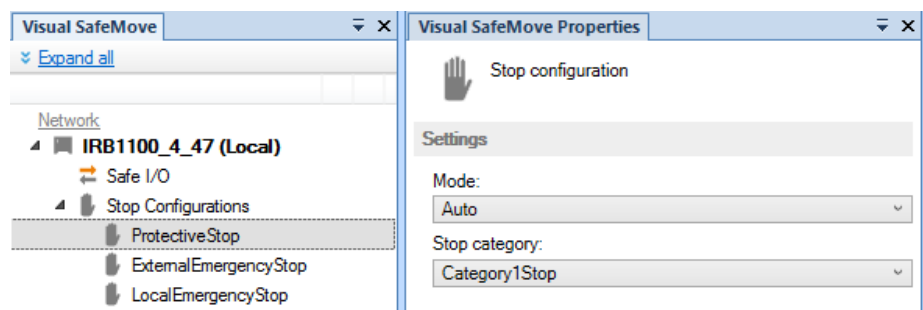

xx2100000737

- 2 Select a stop configuration or right-click to create a new configuration.

Continues on next page

- 3 For user-created stop configurations, select the signal that should trigger the stop in the **Trigger signal** dropdown menu.
 - 0 = activate stop
 - 1 = deactivate stop
- 4 For user-created stop configurations, if a status signal should be set when the functionality is active, select the signal to use in **Stop trigger status** dropdown menu.

If no output signal should be used, select **No signal**.

 - 0 = stop triggered
 - 1 = stop not triggered
- 5 Define the mode (automatic or manual).
 - *ProtectiveStop* is the AS/GS input
 - *ExternalEmergencyStop* is the ES input

To avoid dead-lock in an emergency stop chain, the *ExternalEmergencyStop* input can be decoupled from the ES output.

 - *LocalEmergencyStop* is the emergency stop device on the FlexPendant
- 6 Select the stop category.
- 7 After the configuration is done, the safety configuration must be transferred to the controller and then a restart of the controller is required.



Tip

See also the circuit diagram, *Circuit diagram - OmniCore E10*.

Apply the configuration to the controller

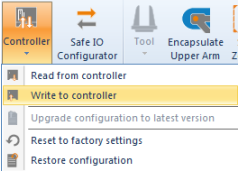
	Action	Note/illustration
1	In the Visual SafeMove ribbon, click on Controller and then select Write to controller .	 <p>xx1500000801</p>
2	A report of the safety configuration is shown. The report can be printed by clicking on Print (it is recommended to print the report since it should be used when validating the configuration). Click OK to close the report.	
3	Answer Yes when asked if you want to restart the controller.	After the restart, the downloaded configuration is active. Before running in auto mode, the configuration should be validated and locked, see Validate the configuration of robot stopping functions on page 100 .

Continues on next page

3 Installation and commissioning

3.5.9 Configuring robot stopping functions

Continued

Validate the configuration of robot stopping functions



DANGER

A stop configuration must always be validated to verify that the desired safety is achieved.

	Action	Expected result
1	Deactivate any supervision functions that are signal activated.	
2	Move the robot, for example with a move instruction.	
3	Set the signal configured to stop the robot in relevant operating modes. Relevant operating modes are: <ul style="list-style-type: none">• Auto: Automatic mode• General: All modes• EmergencyStop: All modes	The robot will stop.

Upgrading RobotWare

When upgrading RobotWare there can be differences in functionality, also when configuring the robot stopping functions. Always read the RobotWare release notes and verify the robot stopping functions by test after an upgrade. Contact your local ABB office for guidance.

RobotWare prior to 7.6

In RobotWare releases prior to 7.6, the ES input cannot be decoupled from the ES output.

The *LocalEmergencyStop* was named *InternalEmergencyStop* prior to RobotWare 7.6.

3.5.10 Programmable stop functions

Stopping functions

There are different methods to stop the robot, in addition to manually initiated stops.

- Stop with system input signals
- Stop with RAPID instructions
- Other stops

Stop with system input signals

In the control system, it is possible to define system input signals to be set/reset through different interactions, for example, through I/O signals. See *Application manual - Controller software OmniCore*.

The RAPID program cannot be started when any of the system input signals is high.

Pre-defined system input	Description
<i>SoftStop</i>	The RAPID program execution is stopped, and the manipulator is stopped on path with no deviation. This stop is similar to a normal program stop using stop button on the FlexPendant.
<i>QuickStop</i>	This is a faster stop of the manipulator than <i>SoftStop</i> . This stop is more stressing for the mechanics than <i>SoftStop</i> , therefore there might be a deviation on path.
<i>Stop at End of Cycle</i>	Stops the RAPID program when the complete program is executed, that means when the last instruction in the main routine has been completed.
<i>Stop at End of Instruction</i>	Stops program execution after the current instruction is completed.

All of these stops are performed without using the brakes, and the power is never disconnected. The program execution can be continued directly, for example by activating a start signal if the stop signal is set low.



Note

Only safety rated input signals are allowed to be used for safety.

Continues on next page

3 Installation and commissioning

3.5.10 Programmable stop functions

Continued

Stop with RAPID instructions

There are several RAPID instructions available that stops the robot.



Instruction	Description	Arguments
SystemStopAction	Stops all robots in all tasks immediately.	<code>\Stop</code> : similar to a normal program stop with stop button. <code>\StopBlock</code> : as above, but to restart the PP has to be moved. <code>\Halt</code> : this is like a category 0 stop, i.e. it will result in motors off state, stop of program execution and robot movements in all motion tasks. The Motors on button must be pressed before the program execution can be restarted.
Stop	The current move instruction will be finished before the robot stops. A restart will continue the program execution.	<code>\NoRegain</code> : the robot will not return to the stop point when restarted, e.g. after having been jogged away. <code>\AllMoveTasks</code> : all robots will be stopped.
StopMove	The current move instruction will be stopped immediately as a normal program stop but the program execution will continue with the next instruction. <code>StartMove</code> must be executed to get the robot moving again.	<code>\AllMotionTasks</code> : all robots will be stopped.
DebugBreak	The current move instruction and the program execution will be stopped immediately as a normal program stop. A restart of the program will continue the program execution.	
EXIT	The current move instruction and the program execution will be stopped immediately as a normal program stop. After stop the Program Pointer is lost and has to be reset to Main.	
EXITCYCLE	The current move instruction and program execution will be stopped immediately. The Program Pointer will be moved to Main and if running mode is continuous, the program will be restarted.	

Continues on next page

Instruction	Description	Arguments
SearchX	Search instructions can be programmed with arguments to stop the robot movement close to the point where a search hit was noticed. The program execution will continue with the next instruction.	<p>\Stop: the robot will stop as fast as possible. This stop is performed by ramping down motion in each motor separate from each other, and as fast as possible. Since it will be without any coordination, the robot may slide off path fairly much.</p> <p>\SStop: the robot will stop on path but quicker than a normal program stop. This is similar to a system input <i>SoftStop</i>.</p> <p>\Sup: the robot will continue to the ToPoint. If more than one search hit is found, an error will be reported.</p>

RAPID instructions are described in *Technical reference manual - RAPID Instructions, Functions and Data types*.

Other unexpected stops

Type of stop	Description
SysFail	In the control system there is a surveillance and monitoring function that can detect abnormal situations. In such cases a stop will be initiated. The robot controller must be restarted.
Power fail	In the control system there is a monitoring function that can detect power failure. In such cases a stop will be initiated.
Stop at collision	<p>In the control system there is a monitoring function that can detect collisions. In such cases a stop will be initiated.</p> <p> WARNING</p> <p>Special care must be taken when restarting a machine that is stopped due to a collision. The robot might make a limited move when restarted.</p> <p> WARNING</p> <p>The revolution counters might need to be updated after a collision to ensure path accuracy.</p>

3 Installation and commissioning

3.6.1 Available industrial networks

3.6 I/O system

3.6.1 Available industrial networks

General



Note

Two industrial network masters can be run in parallel on the OmniCore controller. It is the responsibility of the integrator to verify the behavior when two masters are used in one OmniCore.

Fieldbus connections

The software based fieldbuses are connected directly to one of the Ethernet ports.

Available software based fieldbuses

The following software based fieldbuses are available as RobotWare options.

- EtherNet/IP
- PROFINET
- CC-Link IE Field Basic

References

For more information on how to install and configure the fieldbuses, see the respective manual.

Manual title	Article number
<i>Application manual - EtherNet/IP Scanner/Adapter</i>	3HAC066565-001
<i>Application manual - PROFINET Controller/Device</i>	3HAC066558-001
<i>Application manual - I/O Engineering</i>	3HAC082346-001
<i>Application manual - CC-Link IE Field Basic</i>	3HAC082295-001

3.6.2 Scalable I/O, external

General

The controller can use external I/O units, with DSQC1030 (16 digital inputs and 16 digital outputs) as base unit and add-on units as extension.

Scalable I/O units

The I/O unit *DSQC1030 Digital Base* belongs to the ABB Scalable I/O system, which is a modular, compact, and scalable I/O system that consists of a base device (minimum configuration), and add-on devices.

For information about configuring and using the scalable I/O devices, see *Application manual - Scalable I/O*.

3 Installation and commissioning

3.7.1 Installing Integrated Vision

3.7 Installing add-on devices

3.7.1 Installing Integrated Vision

Required parts



Note

The spare part numbers that are listed in the table can be out of date. See the latest spare parts of the OmniCore E10 via myABB Business Portal, www.abb.com/myABB.

Spare part	Article number	Note
8 mm camera lens, LTC-08F	3HAC053944-001	
12.5 mm camera lens, LFC-12.5F	3HAC053944-002	
16 mm camera lens, LFC-16F1	3HAC053944-003	
25 mm camera lens, LFC-25F1	3HAC053944-004	
Integr Vision camera med. Res	3HAC053953-001	DSQC1020
Integr Vision camera high res	3HAC053954-001	DSQC1021
Integr Vision power cable	3HAC051753-003	
Integr Vision ethernet cable	3HAC051736-003	

Required tools and equipment

Equipment	Article number	Note
Standard toolkit	-	Content is defined in section Standard toolkit for controller on page 212 .
ESD protective wrist band	-	

Required documents

Document	Article number	Note
<i>Circuit diagram - OmniCore E10</i>	3HAC076810-008	
<i>Application manual - Integrated Vision</i>	3HAC067707-001	

Installing Integrated Vision camera connections

	Action	Note/Illustration
1	 DANGER Before doing any work inside the cabinet, disconnect the mains power. For more information, see Electrical safety on page 30 .	

Continues on next page

	Action	Note/Illustration
2	Fit the cameras to the mounting rail (not supplied from ABB).	
3	<p>Connect the Ethernet cable from the camera to the Device port on the computer and logic unit.</p> <p> Tip</p> <p>The MGMT port can be also used for connecting the Ethernet cable for the camera.</p>	
4	Connect the 24V power supply to the cameras from the other power supply.	
5	Connect wires to the inputs and output connectors as required.	See <i>Application manual - Integrated Vision</i> .

For more information about the option *Integrated Vision*, see *Application manual - Integrated Vision*.

3 Installation and commissioning

3.7.2 Installing the scalable I/O devices

3.7.2 Installing the scalable I/O devices

Overview

The base unit is used as a scalable I/O external unit, with or without add-on devices.

To install the scalable I/O add-on devices, the digital base DSQC 1030 must be installed as an external unit.

For more information about installing, configuring, and using the scalable I/O units, see *Application manual - Scalable I/O*.

The scalable I/O add-on devices are shown in the following illustration.

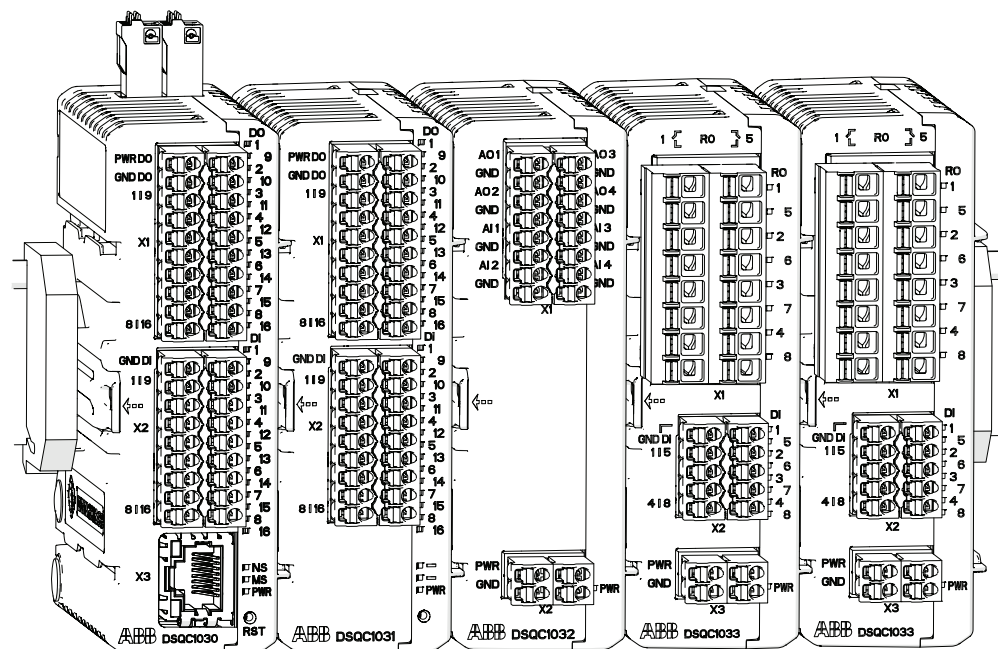

xx1600002032

Required parts

Part	Article number	Note
Scalable I/O Digital base [3032-1]	3HAC058663-001	DSQC1030
Connectors digital base/add on	3HAC060919-001	
Digital add-on [3033-2]	3HAC058664-001	DSQC1031
Analog add-on [3034-2]	3HAC058665-001	DSQC1032
Connectors I/O Analog	3HAC060925-001	
Relay add-on [3035-2]	3HAC058666-001	DSQC1033
Connectors I/O Relay	3HAC060926-001	

Required tools and equipment

Equipment	Article number	Note
Standard toolkit	-	Content is defined in section Standard toolkit for controller on page 212 .

Continues on next page



Equipment	Article number	Note
ESD protective wrist band	-	

Required documents

Document	Article number	Note
<i>Circuit diagram - OmniCore E10</i>	3HAC076810-008	
<i>Application manual - Scalable I/O</i>	3HAC070208-001	

Installing scalable I/O external devices

For more information about installing, configuring, and using the scalable I/O units, see *Application manual - Scalable I/O*.

	Action	Note/Illustration
1	 DANGER Before doing any work inside the cabinet, disconnect the mains power. For more information, see Electrical safety on page 30 .	
2	 ELECTROSTATIC DISCHARGE (ESD) The unit is sensitive to ESD. Before handling the unit read the safety information in section The unit is sensitive to ESD on page 43 .	
3	Prepare the scalable I/O units for external mounting as described in <i>Application manual - Scalable I/O</i> .	
4	Connect the external base device to the main computer (Device), using an Ethernet cable. <ul style="list-style-type: none"> • Device - X3 	
5	Connect an external power supply/ internal power supply from main computer to the external base units. <ul style="list-style-type: none"> • External power supply/24V_IO_EXT - X4 	Each base device requires its own power supply.
6	Perform the function tests to verify that the safety features work properly, see Function tests on page 116 .	

3 Installation and commissioning

3.8 Initial test before commissioning

3.8 Initial test before commissioning

Protective earth

Before supplying power to the robot and commissioning, verify that the cabinet is connected to protective earth according to [Connecting incoming mains and protective earth to the controller on page 79](#).

Function tests

Before commissioning, perform the function tests in section [Function tests on page 116](#) to verify that the safety features work properly.

4 Maintenance

4.1 Maintenance schedule for the OmniCore controller

General

The controller must be maintained at regular intervals to ensure its function. The activities and intervals are described in this section.

Activities and intervals

Equipment	Maintenance activity	Interval	Detailed in section:
Complete controller	Inspection	12 months ⁱ	Inspecting the OmniCore E10 controller on page 112
System fans	Inspection	6 months ⁱ	Inspecting the OmniCore E10 controller on page 112
Control cabinet	Cleaning		Cleaning of the controller cabinet on page 113
FlexPendant	Cleaning	When needed	Cleaning the FlexPendant on page 114
Emergency stop (FlexPendant)	Function test	12 months	Function test of emergency stop on page 116
Manual, auto and manual full speed mode with FlexPendant	Function test	12 months	Function test of manual, auto, and manual full speed mode with FlexPendant on page 117
Enabling device	Function test	12 months	Function test of three-position enabling device on page 118
Safety switches	Function test	12 months	Function test of safety switches on page 119
Auto stop (tested if used)	Function test	12 months	Function test of Automatic Stop on page 120
General stop (tested if used)	Function test	12 months	Function test of General Stop on page 121
External emergency stop (tested if used)	Function test	12 months	Function test of external emergency stop on page 122
ESTOP_STATUS output (tested if used)	Function test	12 months	Function test of ESTOP_STATUS output on page 123
Reduced speed control	Function test	During commissioning	Function test of reduced speed control on page 124.

ⁱ The interval depends on the working environment of the equipment: a cleaner environment may extend the maintenance interval and vice versa.

Function test after replacement of component

After replacing a component in the controller, the function tests should be performed. See [Function tests on page 116](#).



4 Maintenance

4.2.1 Inspection of controller

4.2 Inspection activities

4.2.1 Inspection of controller

Inspecting the OmniCore E10 controller

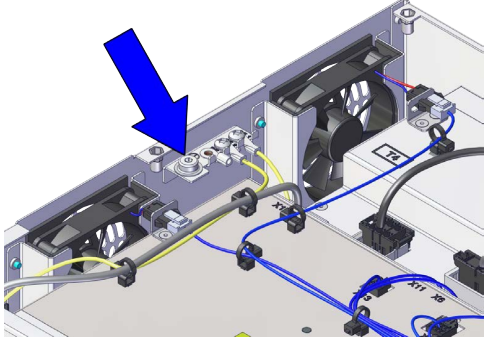
	Action	Note/illustration
1	 DANGER Before doing any work inside the cabinet, disconnect the mains power. For more information, see Electrical safety on page 30 .	
2	 ELECTROSTATIC DISCHARGE (ESD) The unit is sensitive to ESD. Before handling the unit read the safety information in section The unit is sensitive to ESD on page 43 .	Location of wrist strap button:  xx2100001295
3	Inspect connectors and cabling to make sure they are securely fastened and cabling not damaged.	
4	Inspect the fans and ventilation holes to make sure they are clean.	
5	After inspection: Temporarily turn the power supply on. Inspect the fans to make sure they function correctly. Switch the power off.	

4.3 Cleaning activities

4.3.1 Cleaning of the controller cabinet

Required equipment

Equipment, etc.	Note
Vacuum cleaner	ESD protected

Cleaning considerations

This section specifies some special considerations when cleaning the controller.

- Always use ESD protection.
- Always use cleaning equipment as specified above. Any other cleaning equipment may shorten the life of paint work, rust inhibitors, signs, or labels.
- Always make sure that all protective covers are fitted to the controller before cleaning.
- Never remove any covers or other protective devices when cleaning the outside of the controller.
- Never use compressed air or spray with a high pressure cleaner.
- Never leave the door open when cleaning the exterior.

4 Maintenance

4.3.2 Cleaning the FlexPendant

4.3.2 Cleaning the FlexPendant

Location

The surfaces to clean are shown in the illustration below.

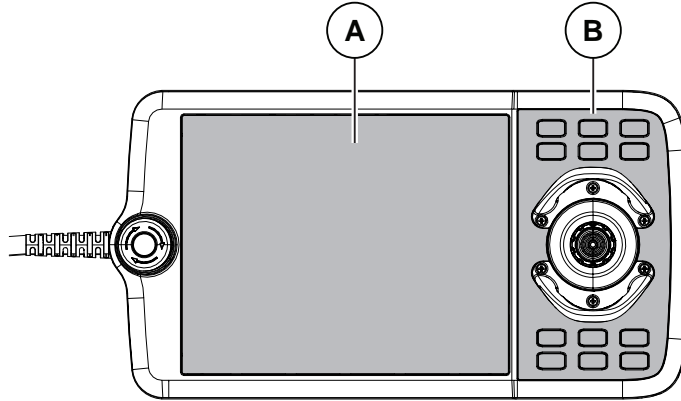

xx180000128

A	Touch screen
B	Hard buttons

Required equipment

Equipment, etc.	Note
Soft cloth	ESD protected
Water/Mild cleaning agent	

Clean the touch screen

This section describes how to clean the touch screen.

	Action	Info/Illustration
1	Lock the screen.	
2	It is safe to clean the FlexPendant when the Lock screen appears.	
3	Clean the touch screen and hardware buttons using a soft cloth and water or a mild cleaning agent.	
4	Unlock the screen, by tapping the buttons.	

Cleaning considerations

The section below specifies some special considerations when cleaning the FlexPendant:

- Use ESD Protection
- Use cleaning equipment as specified above. Any other cleaning equipment may shorten the life time of the touch screen.
- Check that all protective covers are fitted to the device before cleaning.
- Make sure that no foreign objects or liquids can penetrate into the device.

Continues on next page

- Do not remove any covers before cleaning the FlexPendant.
- Do not spray with a high pressure cleaner.
- Do not clean the device, operating panel and operating elements with compressed air, solvents, scouring agent or scrubbing sponges.

4 Maintenance

4.4.1 Function test of emergency stop

4.4 Function tests

4.4.1 Function test of emergency stop

Overview

Validate the function of the FlexPendant emergency stop device.



Note

Also perform the test for any additional emergency stop devices.

Performing the function test

	Action	Note
1	Make a visual inspection of the emergency stop device to make sure it is not physically damaged.	If any damage is found on the emergency stop device, it must be replaced.
2	Pull and rotate the emergency stop device clockwise to verify that it is not pressed in.	
3	Power on the robot.	
4	<p>Press the emergency stop device on the FlexPendant.</p> Note If the event message 20223 Emergency stop conflict appears in the event log, or the event message 10013 Emergency stop state (and 90518 Safety controller Emergency stop triggered for robots prepared for collaborative applications) does not appear, then the test has failed and the root cause of the failure must be found.	<p>The test is passed if the event message 10013 Emergency stop state appears in the event log.</p> <p>If either of the following happens, then the test is failed and the root cause must be found:</p> <ul style="list-style-type: none">• if the event message 10013 Emergency stop state does not appear• if the event message 90780 Two-channel fault in Safety Controller appears Note For robots prepared for collaborative applications, the event message 90518 Safety controller Emergency stop triggered appears by default. The message 10013 Emergency stop state is also available in the event log.
5	Release the emergency stop device to reset the emergency stop state.	

4.4.2 Function test of manual, auto, and manual full speed mode with FlexPendant

Overview

Perform this function test to change the mode on the FlexPendant using the following operation:

- **Status bar > Common Settings > Operating Mode (Auto/Manual/Man FS).**

For more detailed information, see *Operating manual - OmniCore, 3HAC065036-001*.

Performing the function test

	Action	Note
1	Start the robot system.	
2	Change to Automatic operating mode and Motors ON state, and then run the robot in auto mode.	This test is passed if it is possible to run the robot program in auto mode. If it is not possible to run the robot program, this test is failed and the root cause of the failure must be found.
3	Change to Manual operating mode and Motors ON state, and then run the robot in manual mode.	This test is passed if it is possible to run the robot program in manual mode. If it is not possible to run the robot program, this test is failed and the root cause of the failure must be found.
4	Change to Manual Full Speed mode and Motors ON state, and then run the robot in manual full speed mode.  Note Manual full speed mode is not available in USA or Canada.	This test is passed if it is possible to run the robot program in manual full speed mode. If it is not possible to run the robot program, this test is failed and the root cause of the failure must be found.

4 Maintenance

4.4.3 Function test of three-position enabling device

4.4.3 Function test of three-position enabling device

Performing the function test

	Action	Note
1	Start the robot system and turn the mode switch to manual mode.	
2	Press the three-position enabling device to the middle position and then hold the enabling device in this position.	This test is passed if the event message 10011 Motors ON state appears in the event log. If either of the following happens, then the test is failed and the root cause must be found: <ul style="list-style-type: none">• if the event message 10011 Motors ON state does not appear• if the event message 90780 Two-channel fault in Safety Controller appears
3	While still holding the three-position enabling device pressed, press the enabling device harder to the enable the device's third position.	This test is passed if the event message 10012 Safety guard stop state appears in the event log. If either of the following happens, then the test is failed and the root cause must be found: <ul style="list-style-type: none">• if the event message 10012 Safety guard stop state does not appear• if the event message 90780 Two-channel fault in Safety Controller appears

4.4.4 Function test of safety switches

Performing the motor function test

	Action	Note
1	Start the robot system and change the operating mode to manual.	
2	Press the three-position enabling device to the middle position and then hold the enabling device in this position.	This test is passed if the event message 10011 Motors ON state appears in the event log. If the event message 37001 Motor on activation error appears in the event log, then the test has failed and the root cause of the failure must be found.
3	Release the three-position enabling device.	This test is passed if the event message 10012 Safety guard stop state appears in the event log. If the event message 90227 Motor contact or conflict appears in the event log, then the test has failed and the root cause of the failure must be found.

Performing the brake function test

	Action	Note
1	Start the robot system and change the operating mode to manual.	
2	Press the three-position enabling device to the middle position and then hold the enabling device in this position. While having eye contact with the manipulator, move the joystick slightly in any direction to disengage the brakes.	This test is passed if the brakes are disengaged and the manipulator can be moved. If the event message 50056 Joint collision appears in the event log, then the test has failed and the root cause of the failure must be found.
3	Release the three-position enabling device to engage the brakes.	This test is passed if the event message 10012 Safety guard stop state appears in the event log. If the event message 37101 Brake Failure appears in the event log, then the test has failed and the root cause of the failure must be found.

4 Maintenance

4.4.5 Function test of Automatic Stop

4.4.5 Function test of Automatic Stop

Performing the function test

	Action	Note
1	Start the robot system and change the operating mode to auto mode.	
2	Activate the Automatic Stop, for example by opening the connected robot cell door, which has interlock connection with Automatic Stop.	<p>The test is passed if the event message 90523 Safety Controller Protective Stop triggered appears in the event log.</p> <p>If either of the following happens, then the test is failed and the root cause must be found:</p> <ul style="list-style-type: none">• if the event message 90523 Safety Controller Protective Stop triggered does not appear• if the event message 90780 Two-channel fault in Safety Controller appears

4.4.6 Function test of General Stop

Performing the function test

	Action	Note
1	Start the robot system.	
2	Activate the General Stop.	<p>The test is passed if the event message 90523 Safety Controller Protective Stop triggered appears in the event log.</p> <p>If either of the following happens, then the test is failed and the root cause must be found:</p> <ul style="list-style-type: none">• if the event message 90523 Safety Controller Protective Stop triggered does not appear• if the event message 90780 Two-channel fault in Safety Controller appears

4 Maintenance



4.4.7 Function test of external emergency stop

4.4.7 Function test of external emergency stop

Overview

Perform this test on the external emergency stop device.

Performing the function test



	Action	Note
1	Make a visual inspection of the external emergency stop device and the connection harness to make sure they are not physically damaged.	If any damage is found on the external emergency stop device or the connection harness, it must be replaced.
2	<p>Pull and rotate the button on the external emergency stop device clockwise to verify that it is not pressed in.</p> <p> Note</p> <p>If the external emergency stop device is not controlled by a push-button, make sure to verify that it is not activated.</p>	
3	Start the robot system.	
4	Press the emergency stop device.	<p>The test is passed if the event message 10013 Emergency stop state appears in the event log.</p> <p>If the event message 90780 Two-channel fault in Safety Controller appears in the event log, or the event message 10013 Emergency stop state does not appear, then the test has failed and the root cause of the failure must be found.</p> <p> Note</p> <p>The event message 90518 Safety controller Emergency stop triggered appears by default.</p>
5	Release the external emergency stop device to reset the external emergency stop state.	

4.4.8 Function test of ESTOP_STATUS output

Overview

Perform this test on the FlexPendant emergency stop device or the external emergency stop device, with the accessory device.

Performing the function test

	Action	Note
1	Make a visual inspection of the emergency stop device, external emergency stop device, accessory device and the connection harness to make sure they are not physically damaged.	If any damage is found, it must be replaced.
2	Pull and rotate the emergency stop device clockwise to verify that it is not pressed in.  Note If the external emergency stop device is not controlled by a push-button, make sure to verify that it is not activated.	
3	Start the robot system.	
4	Press the emergency stop device.	The test is passed if the event message 10013 Emergency stop state appears in the event log. If the event message 90780 Two-channel fault in Safety Controller appears in the event log, or the event message 10013 Emergency stop state does not appear, then the test has failed and the root cause of the failure must be found.  Note The event message 90518 Safety controller Emergency stop triggered appears by default.
5	Make sure that the accessory device is in emergency stop status.	
6	Release the emergency stop device or the external emergency stop device to reset the emergency stop state.	
7	Make sure that the accessory device is not in emergency stop status any more and can be reset.	

4 Maintenance

4.4.9 Function test of reduced speed control

4.4.9 Function test of reduced speed control

Performing the function test

	Action	Note
1	Start the robot system and change the operating mode to manual.	
2	Create a test program where the robot moves along a known distance with a programmed speed higher than 250 mm/s.	The distance and speed must be adapted to the current installation and robot model.
3	<p>Start the program in manual mode and measure the time it takes for the robot to travel the distance.</p> <p> Tip</p> <p>To get accurate results, use sensors or I/O signals to measure the time.</p>	This test is passed if the speed of the robot does not exceed 250 mm/s, otherwise the test is failed and the root cause of the failure must be found.

5 Repair

5.1 Introduction to repair

Structure of this chapter

This chapter describes all repair activities recommended for the OmniCore E10 and any external unit.

It is made up of separate procedures, each describing a specific repair activity. Each procedure contains all the information required to perform the activity, for example spare parts numbers, required special tools, and materials.

All procedures assume that the controller is easy to access from all sides and that no additional covers or equipment are fitted.



WARNING

Repair activities not described in this chapter must only be carried out by ABB. Otherwise damage to the mechanics and electronics may occur.

Required equipment

The details of the equipment required to perform a specific repair activity are listed in the respective procedures.

Safety information

Read chapter [Safety on page 15](#) before commencing any service work.



WARNING

Wait at least three minutes after powering off the controller before opening it and at least fifteen minutes until all LED indicators are off before replacing modules. Allow the surfaces to cool down before maintenance or repair.



Note

When replacing a part on the OmniCore E10, report to your local ABB the serial number, the article number, and the revision of both the replaced unit and the replacement unit.

This is particularly important for safety equipment to maintain the safety integrity of the installation.

5 Repair

5.2.1 Opening the robot controller

5.2 Replacing parts inside the controller

5.2.1 Opening the robot controller

Required tools and equipment

Equipment	Article number	Note
Standard toolkit	-	Content is defined in section Standard toolkit for controller on page 212 .
ESD protective wrist band	-	

Required documents

Document	Article number	Note
<i>Circuit diagram - OmniCore E10</i>	3HAC076810-008	

Removing the controller top cover

Preparations

Action	Info/illustration
1  DANGER Before doing any work inside the cabinet, disconnect the mains power. For more information, see Electrical safety on page 30 .	

Removing the top cover

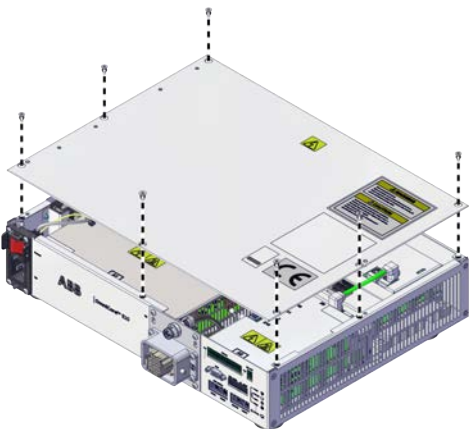
Action	Info/illustration
1 Remove the attachment screws.	 xx2100001329
2 Remove the top cover.	

Continues on next page

Refitting the controller cover

Preparations

	Action	Info/illustration
1	 DANGER Before doing any work inside the cabinet, disconnect the mains power. For more information, see Electrical safety on page 30 .	

Refitting the top cover

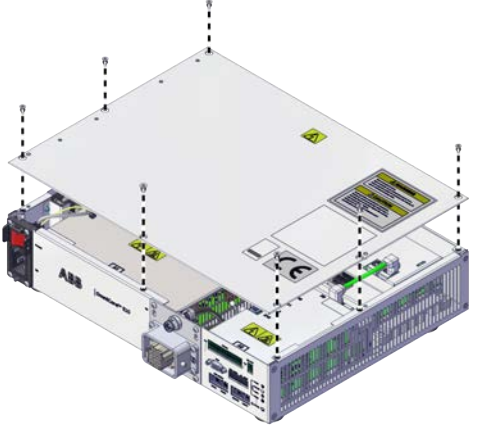
	Action	Info/illustration
1	Refit the top cover using the location pins.	Screws: Torx, countersunk screw M4x10 (7 pcs)
2	Secure it with the screws.	Tightening torque: 1.7 Nm±10%.  xx2100001329

5 Repair

5.2.2 Replacing the fans

5.2.2 Replacing the fans

Location

The illustration shows the location of the fans in the controller.

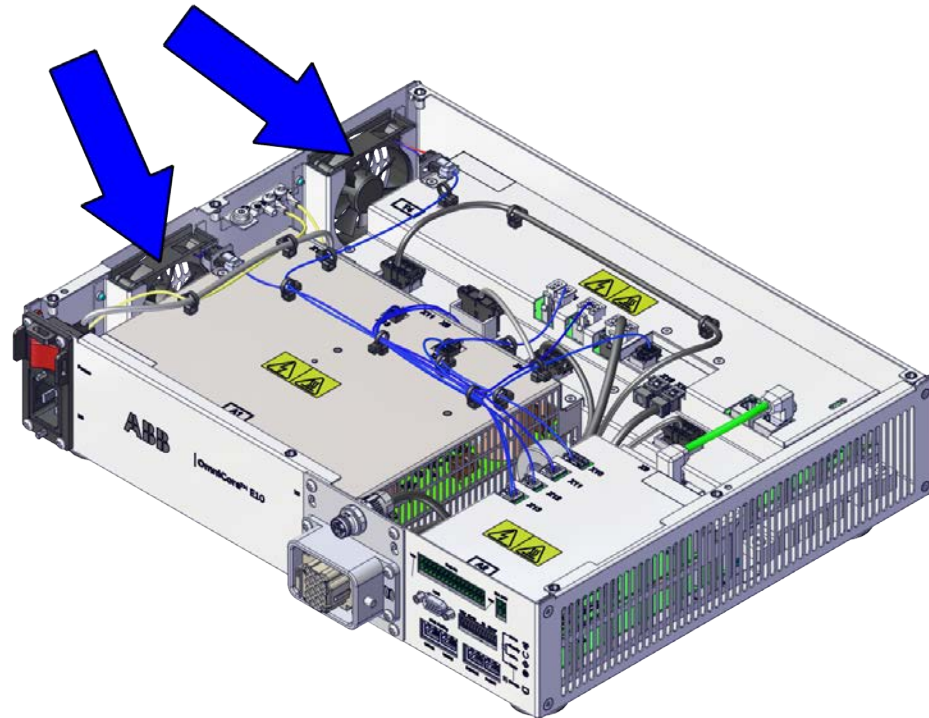

xx2100001326

Required spare parts



Note

The spare part numbers that are listed in the table can be out of date. See the latest spare parts of the OmniCore E10 via myABB Business Portal, www.abb.com/myABB.

Spare part	Article number	Note
Small fan	3HAC078273-001	
Fan bracket assembly	3HAC078981-001	
Fan pressure bracket assembly	3HAC078983-001	

Required tools and equipment

Equipment	Article number	Note
Standard toolkit	-	Content is defined in section Standard toolkit for controller on page 212 .
ESD protective wrist band	-	

Continues on next page

Required documents

Document	Article number	Note
<i>Circuit diagram - OmniCore E10</i>	<i>3HAC076810-008</i>	

Continues on next page



5 Repair

5.2.2.1 Replacing the small fans

5.2.2.1 Replacing the small fans

Removing the small fan

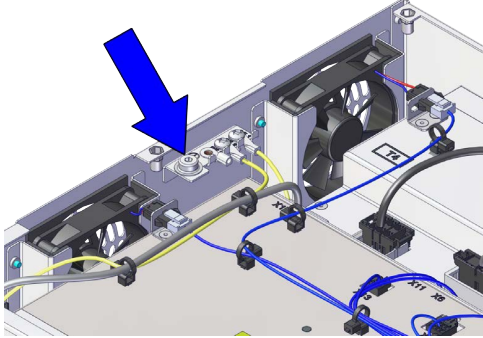

Preparations

	Action	Note/Illustration
1	 DANGER Before doing any work inside the cabinet, disconnect the mains power. For more information, see Electrical safety on page 30 .	
2	 ELECTROSTATIC DISCHARGE (ESD) The unit is sensitive to ESD. Before handling the unit read the safety information in section The unit is sensitive to ESD on page 43 .	Location of wrist strap button:  <small>xx2100001295</small>
3	Remove the top cover of the controller.	Removing the controller top cover on page 126 .

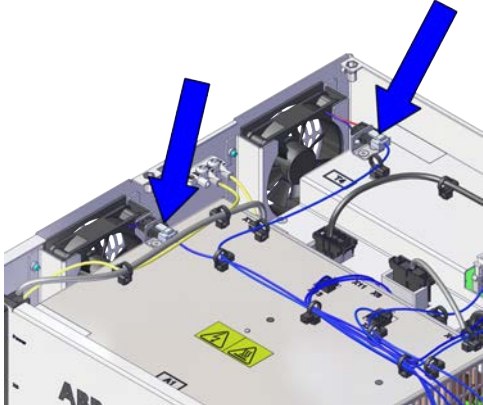
Removing the small fan

	Action	Note/Illustration
1	Disconnect: <ul style="list-style-type: none"> • G1/G2.X1 	 <small>xx2100001330</small>

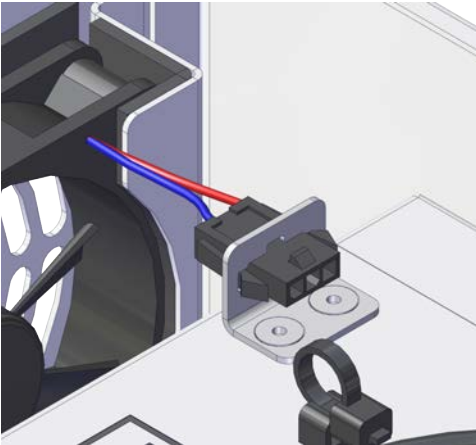
Continues on next page

	Action	Note/Illustration
2	Release the connector from the bracket.	 <p data-bbox="956 763 1062 786">xx2100001331</p>
3	Pull the fan and lift it out.	 <p data-bbox="956 1272 1062 1294">xx2100001332</p>

Refitting the small fan

Refitting the small fan

	Action	Note/Illustration
1	 <p data-bbox="592 1541 699 1570">DANGER</p> <p data-bbox="501 1603 946 1711">Before doing any work inside the cabinet, disconnect the mains power. For more information, see Electrical safety on page 30.</p>	

Continues on next page

5 Repair

5.2.2.1 Replacing the small fans

Continued

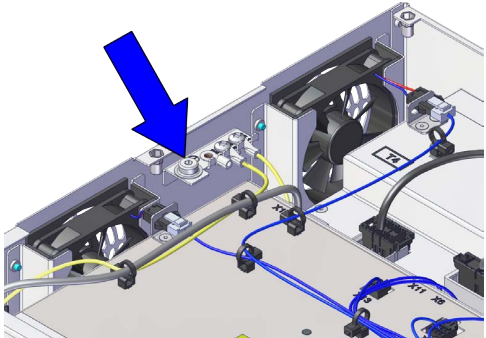
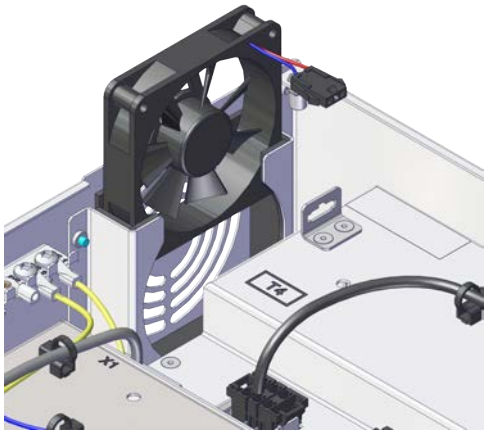
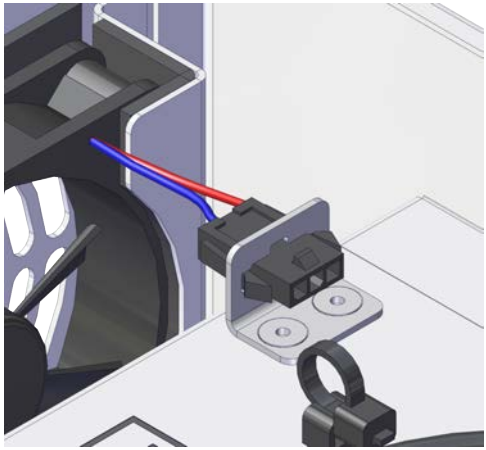
	Action	Note/Illustration
2	<p> ELECTROSTATIC DISCHARGE (ESD)</p> <p>The unit is sensitive to ESD. Before handling the unit read the safety information in section <i>The unit is sensitive to ESD on page 43</i>.</p>	<p>Location of wrist strap button:</p>  <p>xx2100001295</p>
3	<p>Refit the fan into the fan bracket assembly.</p>	 <p>xx2100001332</p>
4	<p>Insert the connector to the bracket.</p>	 <p>xx2100001331</p>

Continues on next page

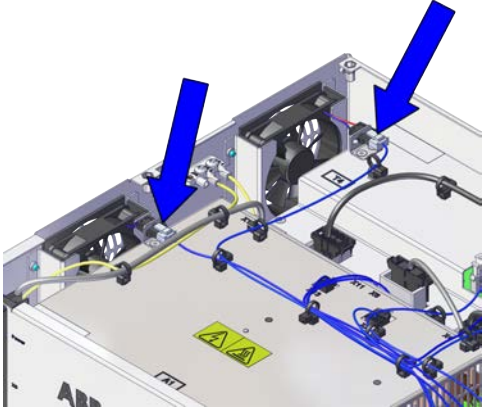
	Action	Note/Illustration
5	Reconnect: <ul style="list-style-type: none"> • G1/G2.X1 	 <p>xx2100001330</p>

Concluding procedure

	Action	Note/Illustration
1	Refit the top cover.	Refitting the controller cover on page 127.
2	Perform the function tests to verify that the safety features work properly, see Function tests on page 116.	

5 Repair

5.2.3 Replacing the power unit

5.2.3 Replacing the power unit

Location

The illustration shows the location of the power unit in the controller.

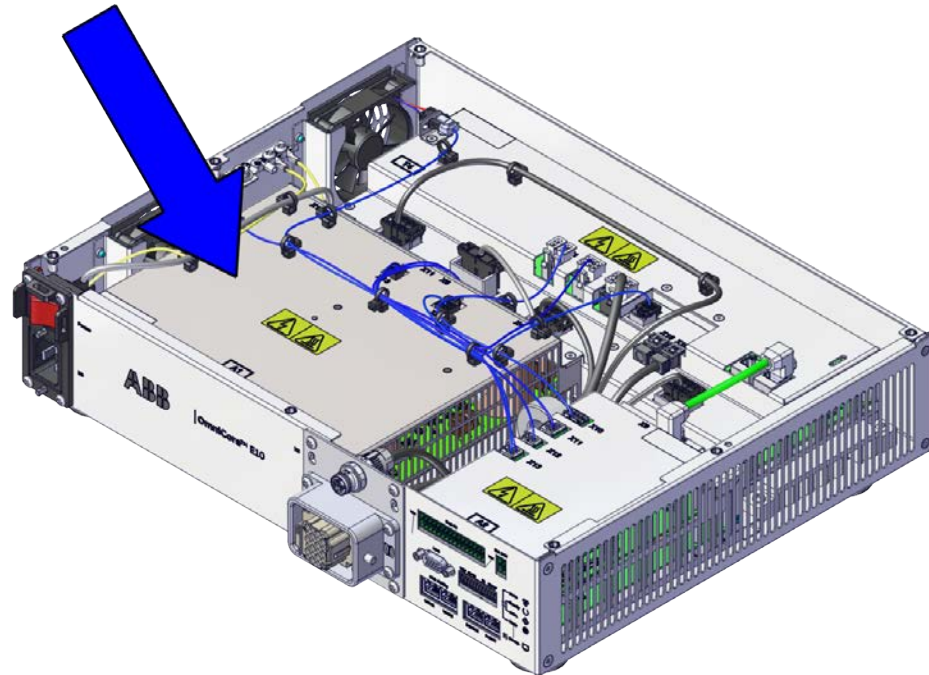

xx2100001324

Required spare parts



Note

The spare part numbers that are listed in the table can be out of date. See the latest spare parts of the OmniCore E10 via myABB Business Portal, www.abb.com/myABB.

Spare part	Article number	Note
Power unit	3HAC074985-001	DSQC3087
Harness Signal cable assembly	3HAC078253-001	

Required tools and equipment

Equipment	Article number	Note
Standard toolkit	-	Content is defined in section Standard toolkit for controller on page 212 .
ESD protective wrist band	-	



Continues on next page

Required documents

Document	Article number	Note
Circuit diagram - OmniCore E10	3HAC076810-008	

Removing the power unit

Preparations

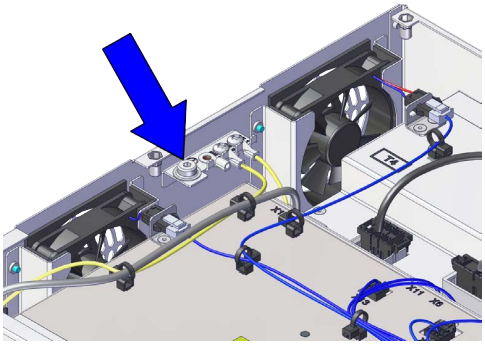
	Action	Note/Illustration
1	 <p>DANGER</p> <p>Before doing any work inside the cabinet, disconnect the mains power. For more information, see Electrical safety on page 30.</p>	
2	 <p>ELECTROSTATIC DISCHARGE (ESD)</p> <p>The unit is sensitive to ESD. Before handling the unit read the safety information in section The unit is sensitive to ESD on page 43.</p>	<p>Location of wrist strap button:</p>  <p>xx2100001295</p>
3	Remove the top cover of the controller.	Removing the controller top cover on page 126 .

Removing the incoming mains connector

	Action	Note/Illustration
1	<p>Disconnect:</p> <ul style="list-style-type: none"> • Q0 - A1.X1. • Two ground cables which connects to the left cabinet frame. 	
2	<p>Pull the cable ties out from the locking holes.</p> <p> Tip</p> <p>Take photos of the cable ties and locking holes before pulling out, to have as a reference when refitting the cable ties.</p>	

Continues on next page

5 Repair

5.2.3 Replacing the power unit

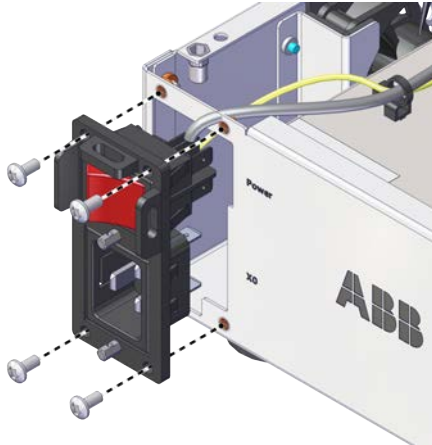

Continued

	Action	Note/Illustration
3	Remove the attachment screws.	 <p data-bbox="924 763 1031 786">xx2100001339</p>
4	Take out the incoming mains connector.	

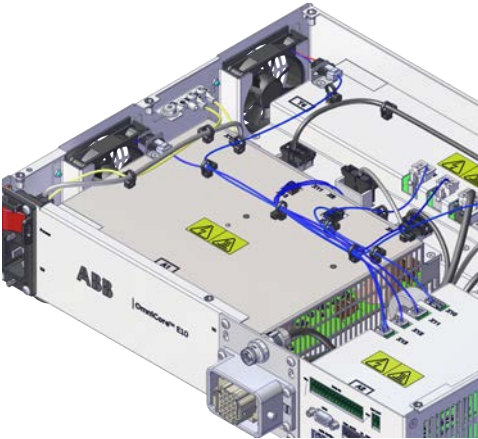
Removing the power unit

	Action	Note/Illustration
1	<p data-bbox="469 981 900 1037">Pull the cable ties out from the locking holes.</p> <p data-bbox="469 1055 600 1122">  Tip </p> <p data-bbox="469 1137 916 1216">Take photos of the cable ties and locking holes before pulling out, to have as a reference when refitting the cable ties.</p>	 <p data-bbox="924 1435 1031 1458">xx2100001333</p>
2	<p data-bbox="469 1496 608 1518">Disconnect:</p> <ul data-bbox="504 1525 751 1671" style="list-style-type: none"> • A1.X13 - A2.X12 • A1.X2 - T4.X17 • A1.X11 - T4.X13 • A2.X13 - G1/G2.X1 • A1.X6 - A2.X11 	

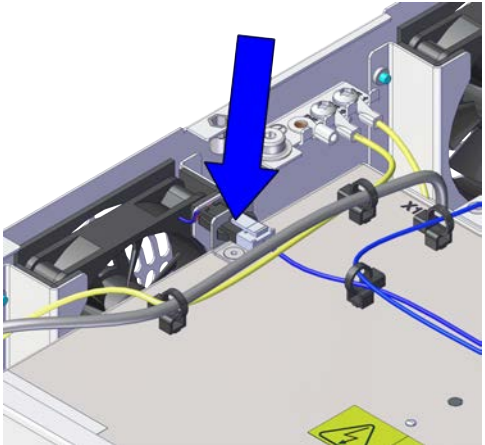
Continues on next page

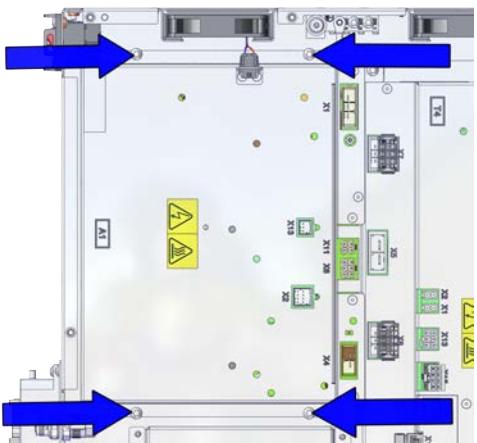
	Action	Note/Illustration
3	Release the fan connector from the bracket.	 <p>xx2100001334</p>
4	Remove the screws and pull the power unit out from the bottom.  CAUTION Only the sheet metal on the power unit can be used for holding. Do not touch the connectors or the filter on the power unit.	 <p>xx2100001335</p>

Refitting the power unit

Refitting the power unit

	Action	Note/Illustration
1	 DANGER Before doing any work inside the cabinet, disconnect the mains power. For more information, see Electrical safety on page 30 .	

Continues on next page

5 Repair

5.2.3 Replacing the power unit

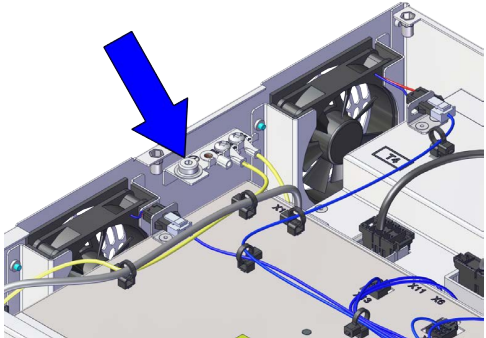
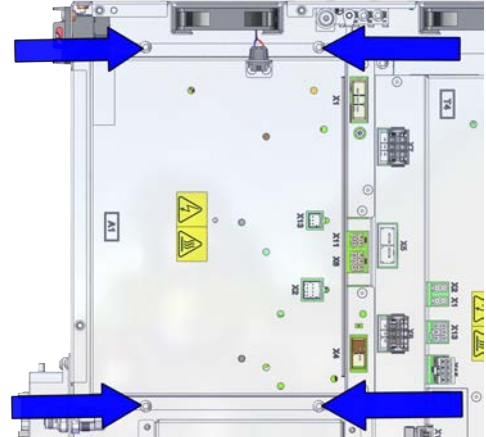
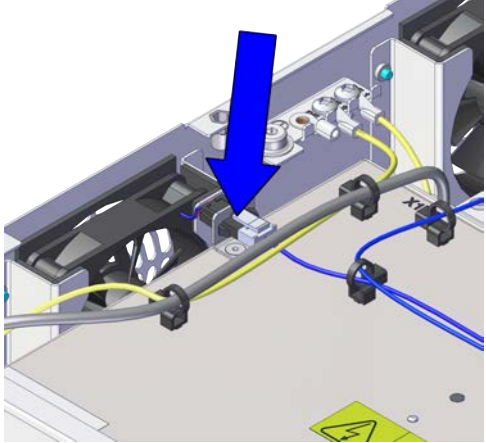

Continued

	Action	Note/Illustration
2	<p> ELECTROSTATIC DISCHARGE (ESD)</p> <p>The unit is sensitive to ESD. Before handling the unit read the safety information in section <i>The unit is sensitive to ESD on page 43</i>.</p>	<p>Location of wrist strap button:</p>  <p>xx2100001295</p>
3	<p>Refit the power unit and secure with the screws.</p>	<p>Screws: Torx pan head screw M4x8 (4 pcs) Tightening torque: 1.7 Nm±10%</p>  <p>xx2100001335</p>
4	<p>Insert the fan connector to the bracket.</p>	 <p>xx2100001334</p>

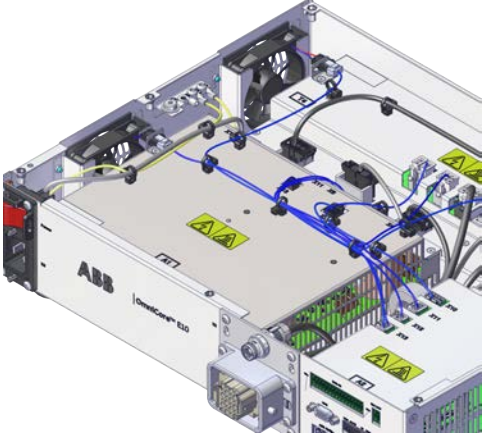
Continues on next page

	Action	Note/Illustration
5	Reconnect: <ul style="list-style-type: none"> • A1.X13 - A2.X12 • A1.X2 - T4.X17 • A1.X11 - T4.X13 • A2.X13 - G1/G2.X1 • A1.X6 - A2.X11 	
6	Insert the cable ties back to the locking holes.  Tip Refit the cable ties according to the photo.	 <p>xx2100001333</p>

Refitting the incoming mains connector

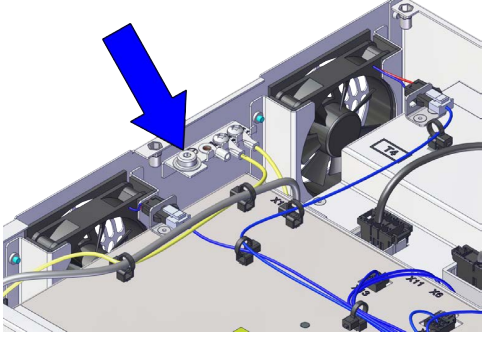
	Action	Note/Illustration
1	 DANGER Before doing any work inside the cabinet, disconnect the mains power. For more information, see Electrical safety on page 30 .	
2	 ELECTROSTATIC DISCHARGE (ESD) The unit is sensitive to ESD. Before handling the unit read the safety information in section The unit is sensitive to ESD on page 43 .	Location of wrist strap button:  <p>xx2100001295</p>
3	Insert the incoming mains connector into the front panel of the cabinet.	

Continues on next page

5 Repair

5.2.3 Replacing the power unit

Continued

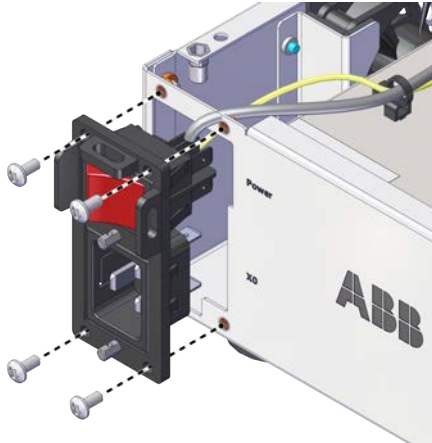
	Action	Note/Illustration
4	Secure it with the screws.	<p>Screws: Torx pan head screw M4x8 (4 pcs) Tightening torque: 1.7 Nm±10%.</p>  <p>xx2100001339</p>
5	Reconnect: <ul style="list-style-type: none"> • Q0 - A1.X1. • Two ground cables which connects to the left cabinet frame. 	

Concluding procedure

	Action	Note/Illustration
1	Refit the top cover.	Refitting the controller cover on page 127.
2	Perform the function tests to verify that the safety features work properly, see Function tests on page 116.	

5.2.4 Replacing the drive unit

Location

The illustration shows the location of the drive unit in the controller.

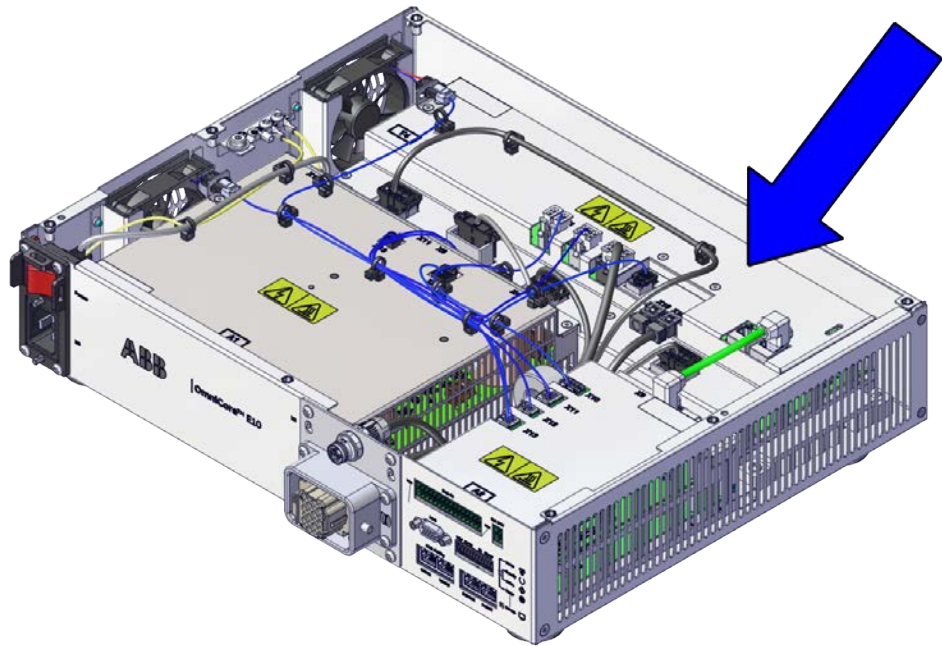

xx2100001323

Required spare parts



Note

The spare part numbers that are listed in the table can be out of date. See the latest spare parts of the OmniCore E10 via myABB Business Portal, www.abb.com/myABB.

Spare part	Article number	Note
Drive unit	3HAC074966-001	DSQC3084
Harness DC-BUS	3HAC075385-001	
Harness EtherCAT	3HAC075387-001	
Harness 24_SYS	3HAC075386-001	
Harness Signal cable assembly	3HAC078253-001	

Continues on next page

5 Repair

5.2.4 Replacing the drive unit

Continued

Required tools and equipment



Equipment	Article number	Note
Standard toolkit	-	Content is defined in section Standard toolkit for controller on page 212 .
ESD protective wrist band	-	

Required documents

Document	Article number	Note
<i>Circuit diagram - OmniCore E10</i>	3HAC076810-008	

Removing the drive unit

Preparations

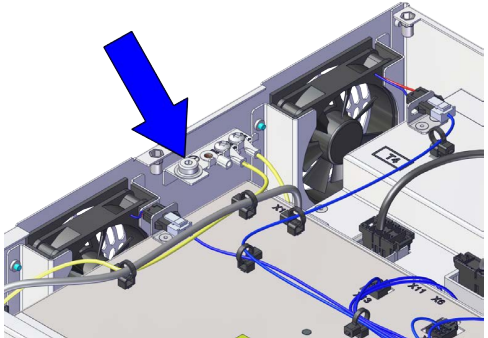
	Action	Note/Illustration
1	 DANGER Before doing any work inside the cabinet, disconnect the mains power. For more information, see Electrical safety on page 30 .	
2	 ELECTROSTATIC DISCHARGE (ESD) The unit is sensitive to ESD. Before handling the unit read the safety information in section The unit is sensitive to ESD on page 43 .	Location of wrist strap button:  <small>xx2100001295</small>
3	Remove the top cover of the controller.	Removing the controller top cover on page 126 .

Continues on next page

Removing the drive unit

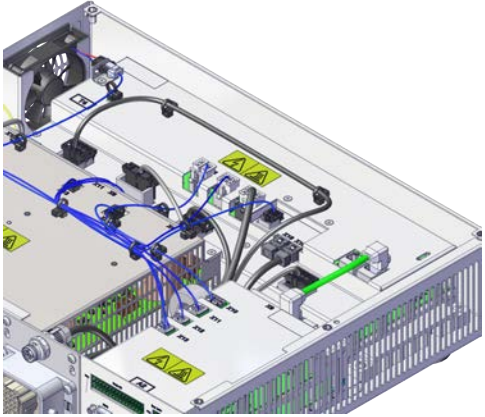
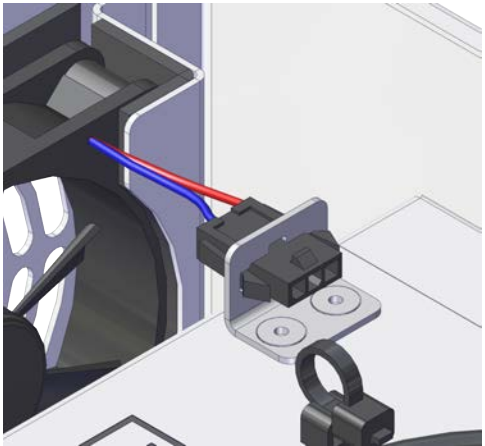
	Action	Note/Illustration
1	<p>Pull the cable ties out from the locking holes.</p> <p> Tip</p> <p>Take photos of the cable ties and locking holes before pulling out, to have as a reference when refitting the cable ties.</p>	 <p>xx2100001336</p>
2	<p>Disconnect:</p> <ul style="list-style-type: none"> • X1 - T4.X7, T4.X8, T4.X9, T4.X15 • X2 - T4.X16 • A1.X2 - T4.X17 • A1.X11 - T4.X13 • A2.X13 - G1/G2.X1 • T4.X5 - A1.X4 • T4.X3 - A2.X9 • T4.X1 - A2.X10 	
3	<p>Release the fan connector from the bracket.</p>	 <p>xx2100001331</p>

Continues on next page

5 Repair

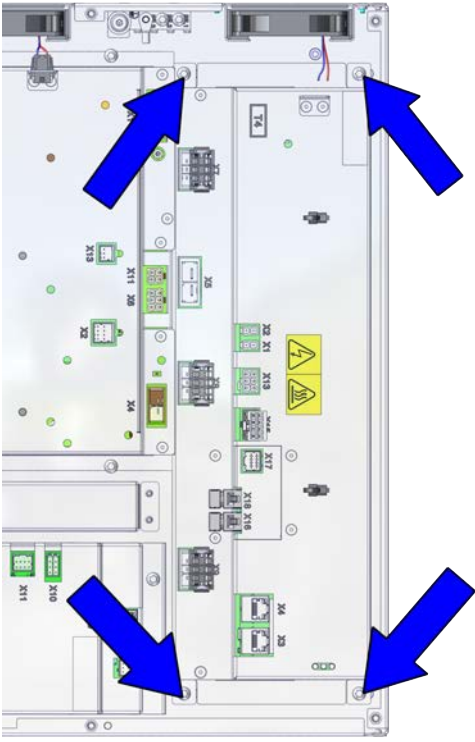

5.2.4 Replacing the drive unit

Continued

	Action	Note/Illustration
4	Remove the screws and pull the drive unit out from the bottom.	<p>Lengthened screwdriver</p>  <p>xx2100001337</p>

Refitting the drive unit

Refitting the drive unit

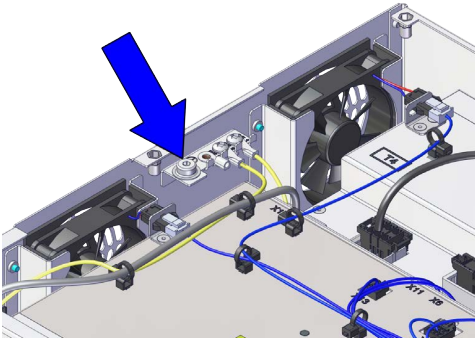
	Action	Note/Illustration
1	 <p>DANGER</p> <p>Before doing any work inside the cabinet, disconnect the mains power. For more information, see Electrical safety on page 30.</p>	
2	 <p>ELECTROSTATIC DISCHARGE (ESD)</p> <p>The unit is sensitive to ESD. Before handling the unit read the safety information in section The unit is sensitive to ESD on page 43.</p>	<p>Location of wrist strap button:</p>  <p>xx2100001295</p>

Continues on next page

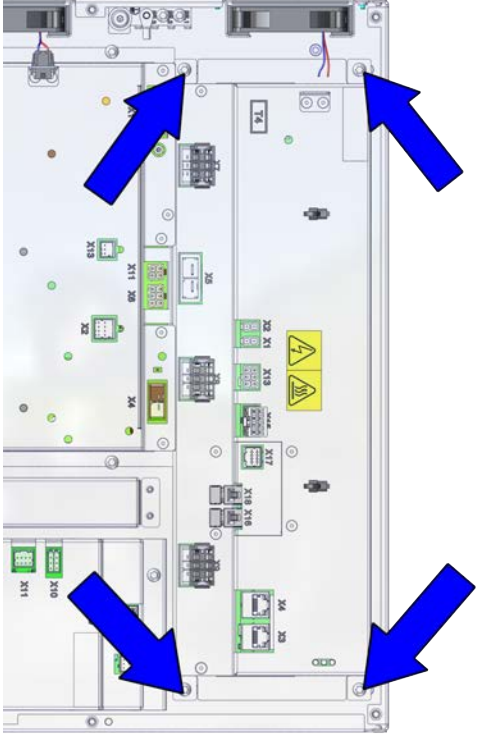
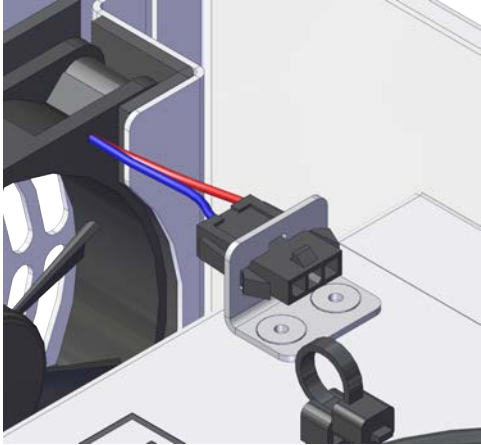
	Action	Note/Illustration
3	Refit the drive unit and secure with the screws.	<p>Screws: Torx pan head screw M4x8 (4 pcs) Tightening torque: 1.7 Nm±10%</p>  <p>xx2100001337</p>
4	Insert the fan connector to the bracket.	 <p>xx2100001331</p>
5	<p>Reconnect:</p> <ul style="list-style-type: none"> • X1-T4.X7, T4.X8, T4.X9, T4.X15 • X2-T4.X16 • A2.X13 - G1/G2.X1 • T4.X5 - A1.X4 • T4.X3 - A2.X9 • T4.X1 - A2.X10 	

Continues on next page

5 Repair

5.2.4 Replacing the drive unit

Continued

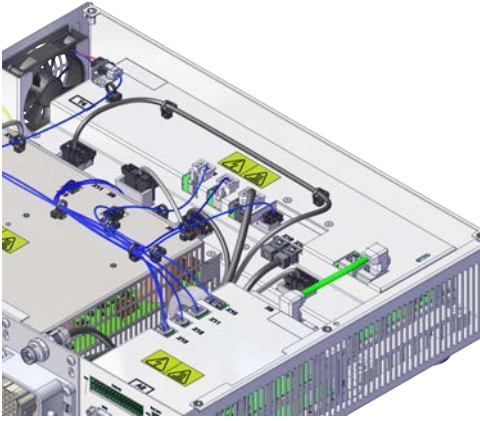
	Action	Note/Illustration
6	<p>Insert the cable ties back to the locking holes.</p> <p> Tip</p> <p>Refit the cable ties according to the photo.</p>	 <p>xx2100001336</p>

Concluding procedure

	Action	Note/Illustration
1	Refit the top cover.	Refitting the controller cover on page 127.
2	Perform the function tests to verify that the safety features work properly, see Function tests on page 116.	

5.2.5 Replacing the computer and logic unit

Location

The illustration shows the location of the computer and logic unit in the controller.

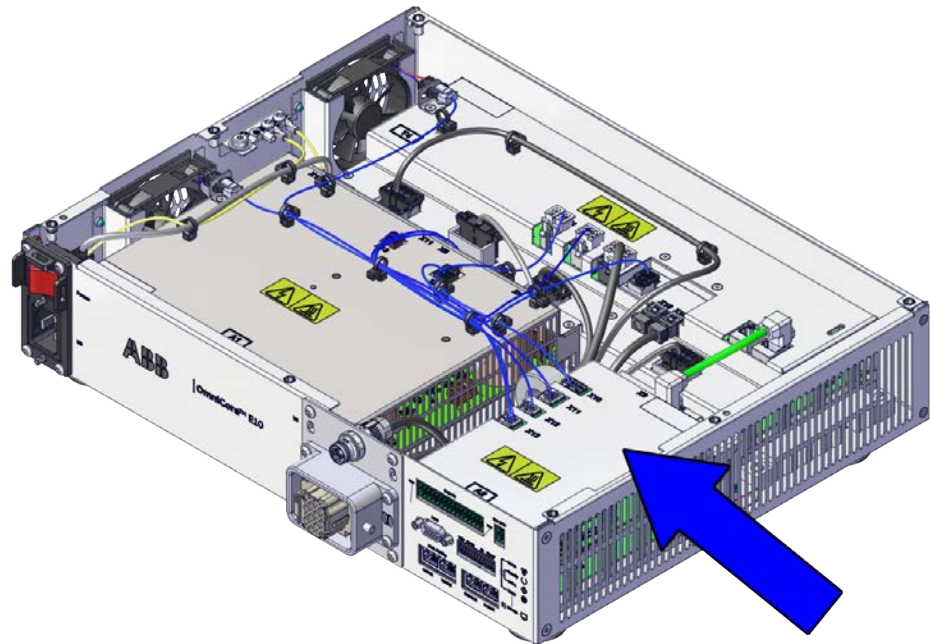

xx2100001325

Required spare parts



Note

The spare part numbers that are listed in the table can be out of date. See the latest spare parts of the OmniCore E10 via myABB Business Portal, www.abb.com/myABB.

Spare part	Article number	Note
Computer and logic unit	3HAC074970-001	DSQC3090
Harness Signal cable assembly	3HAC078253-001	

Required tools and equipment



Note

For robots with the controller delivered to start in automatic mode, a FlexPendant is required after the replacement to be able to change to automatic mode.

Continues on next page

5 Repair

5.2.5 Replacing the computer and logic unit

Continued



Equipment	Article number	Note
Standard toolkit	-	Content is defined in section Standard toolkit for controller on page 212 .
ESD protective wrist band	-	

Required documents

Document	Article number	Note
<i>Circuit diagram - OmniCore E10</i>	3HAC076810-008	

Removing the computer and logic unit

Preparations

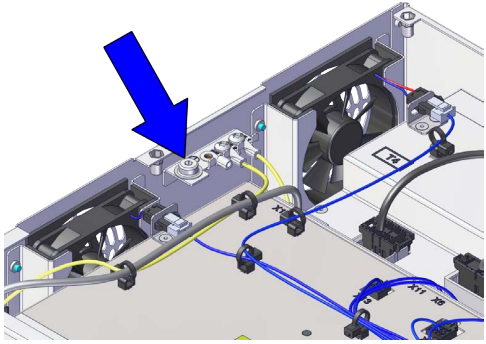

	Action	Note/Illustration
1	 DANGER Before doing any work inside the cabinet, disconnect the mains power. For more information, see Electrical safety on page 30 .	
2	 ELECTROSTATIC DISCHARGE (ESD) The unit is sensitive to ESD. Before handling the unit read the safety information in section The unit is sensitive to ESD on page 43 .	Location of wrist strap button:  xx2100001295
3	Remove the top cover of the controller.	Removing the controller top cover on page 126 .

Continues on next page

Disconnecting the connectors to the computer and logic unit

	Action	Note/Illustration
1	<p>Disconnect:</p> <ul style="list-style-type: none"> • A2.X9 - T4.X3 • A2.X10 - T4.X1 • A1.X6 - A2.X11 • A1.X13 - A2.X12 • A2.X13 - G1/G2.X1 • A2.X14 - X111 <p> Note</p> <p>This connector is used on controller with design front.</p>	

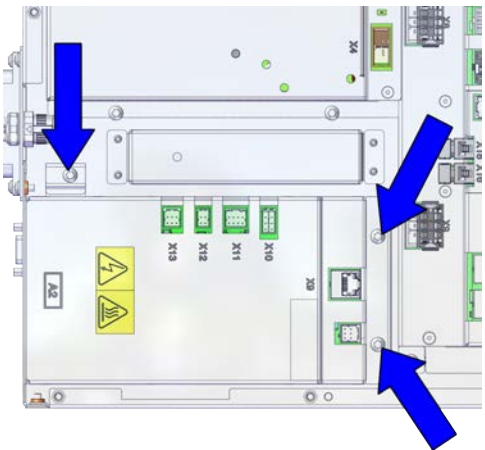
Removing the computer and logic unit

	Action	Note/Illustration
1	<p>Remove the screws locking the computer and logic unit.</p>	 <p>xx2100001338</p>
2	<p>Move the computer and logic unit back a little to release the FlexPendent adaptor connector from the front panel.</p>	
3	<p>Remove the computer and logic unit.</p> <p> ELECTROSTATIC DISCHARGE (ESD)</p> <p>When handling the computer outside of the controller, use the wrist strap button located on the side of the computer.</p>	

Continues on next page



5 Repair

5.2.5 Replacing the computer and logic unit

Continued



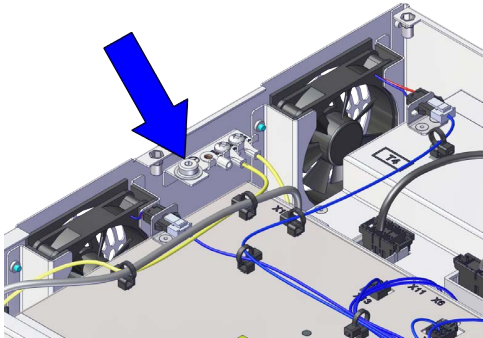
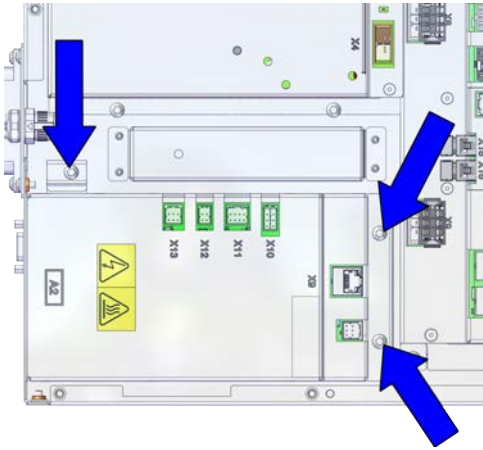

Refitting the computer and logic unit

Refitting the computer and logic unit

	Action	Note/Illustration
1	 <p>DANGER</p> <p>Before doing any work inside the cabinet, disconnect the mains power. For more information, see Electrical safety on page 30.</p>	
2	 <p>ELECTROSTATIC DISCHARGE (ESD)</p> <p>The unit is sensitive to ESD. Before handling the unit read the safety information in section The unit is sensitive to ESD on page 43.</p>	<p>Location of wrist strap button:</p>  <p>xx2100001295</p>
3	Fit the computer and logic unit to the bottom.	
4	Move the computer and logic unit to the locking position.	
5	Fasten the computer and logic unit with the screws.	<p>Screws: Torx pan head screw M4x8 (3 pcs) Tightening torque: 1.7 Nm±10%</p>  <p>xx2100001338</p>

Continues on next page

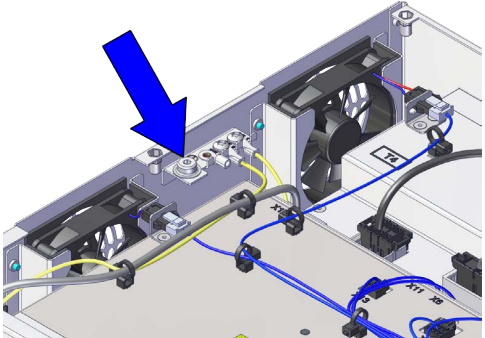
Reconnecting the connectors to the computer and logic unit

	Action	Note/Illustration
1	 <p>DANGER</p> <p>Before doing any work inside the cabinet, disconnect the mains power. For more information, see Electrical safety on page 30.</p>	
2	 <p>ELECTROSTATIC DISCHARGE (ESD)</p> <p>When handling the computer outside of the controller, use the wrist strap button located on the side of the computer.</p>	<p>Location of wrist strap button:</p>  <p>xx2100001295</p>
3	<p>Reconnect:</p> <ul style="list-style-type: none"> • A2.X9 - T4.X3 • A2.X10 - T4.X1 • A1.X6 - A2.X11 • A1.X13 - A2.X12 • A2.X13 - G1/G2.X1 • A2.X14 - X111  <p>Note</p> <p>This connector is used on controller with design front.</p>	

Concluding procedure

	Action	Note/Illustration
1	Refit the top cover.	Refitting the controller cover on page 127 .
2	Restore the hardware settings.	Restoring the hardware settings on page 152 .
3	Perform the function tests to verify that the safety features work properly, see Function tests on page 116 .	

Continues on next page

5 Repair

5.2.5 Replacing the computer and logic unit

Continued



Restoring the hardware settings

The controller hardware settings include information such as controller type and serial number. When the computer and logic unit has been replaced, the serial number must be restored before any software can be installed, or any licences can be imported.



Note

When replacing the computer and logic unit, both the serial number and licences are lost. The serial number must be restored as described below. Licences however, can either be restored automatically when the RobotWare system is installed, or manually through **Manage Licences** in RobotWare Installation Utilities.

	Action	Note/Illustration
1	Download the hardware information file (hwsettings.rsf) from MyABB, or from a previous system backup.	
2	Access the RobotWare Installation Utilities.	 <p>xx1900000110</p>
3	Tap Advanced , and then Restore Hardware Settings .	
4	The Restore Hardware Settings window is displayed. Follow the instructions and tap Next to proceed.	
5	Carefully read the information and then check all boxes to confirm that you agree with the ABB conditions. Tap Next to proceed.	
6	Read the serial number on the front of the controller and type it in field Serial Number . Tap Next .	 <p>xx2000000007</p>

Continues on next page

	Action	Note/Illustration
7	Tap Browse to open the hardware information file from its location. The restoration of the serial number is completed.	The system compares the downloaded file and the manually entered serial number to ensure that there is a match.

5 Repair

5.3.1 Replacing the manipulator signal (SMB) and motors power unit harness assembly

5.3 Replacing parts on the front panel

5.3.1 Replacing the manipulator signal (SMB) and motors power unit harness assembly

Location

The illustration shows the location of the manipulator signal (SMB) and motors power unit harness assembly

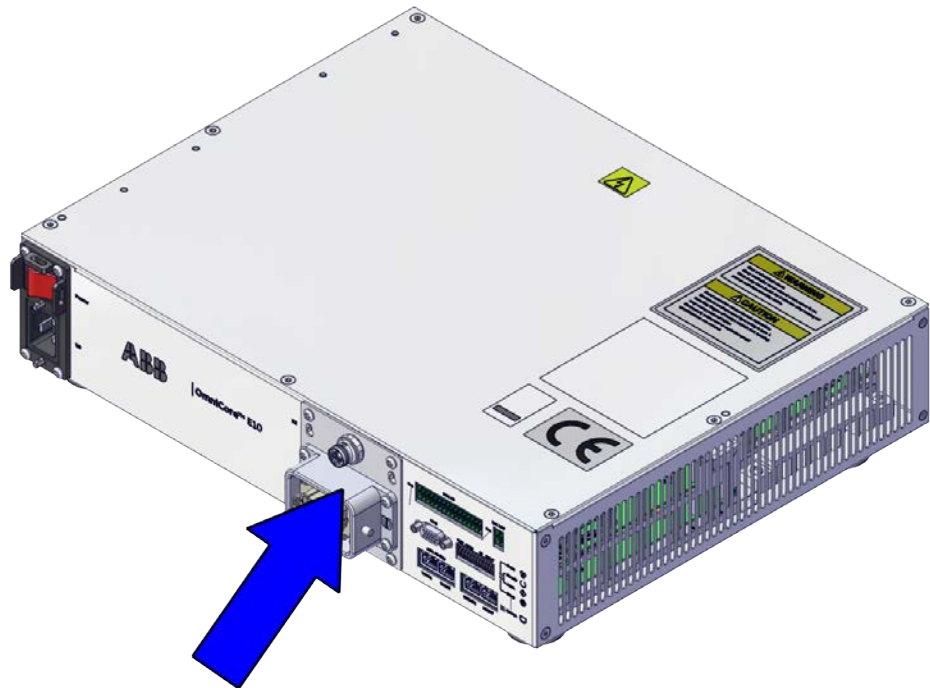

xx2100001327

Required spare parts



Note

The spare part numbers that are listed in the table can be out of date. See the latest spare parts of the OmniCore E10 via myABB Business Portal, www.abb.com/myABB.

Spare part	Article number	Note
Harness assembly SMB+Motors power unit	3HAC075553-001	

Continues on next page

5.3.1 Replacing the manipulator signal (SMB) and motors power unit harness assembly
Continued

Required tools and equipment



Equipment	Article number	Note
Standard toolkit	-	Content is defined in section Standard toolkit for controller on page 212 .
ESD protective wrist band	-	

Required documents

Document	Article number	Note
Circuit diagram - OmniCore E10	3HAC076810-008	

Removing the manipulator signal (SMB) and motors power unit harness assembly

Preparations

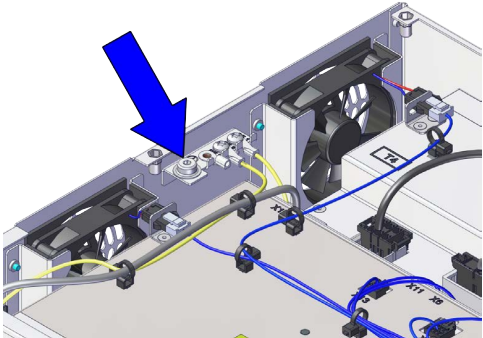
	Action	Note/Illustration
1	 <p>DANGER</p> <p>Before doing any work inside the cabinet, disconnect the mains power. For more information, see Electrical safety on page 30.</p>	
2	 <p>ELECTROSTATIC DISCHARGE (ESD)</p> <p>The unit is sensitive to ESD. Before handling the unit read the safety information in section The unit is sensitive to ESD on page 43.</p>	<p>Location of wrist strap button:</p>  <p>xx2100001295</p>
3	Remove the top cover of the controller.	Removing the controller top cover on page 126 .

Continues on next page

5 Repair

5.3.1 Replacing the manipulator signal (SMB) and motors power unit harness assembly

Continued

Disconnecting the connectors to the computer and logic unit

	Action	Note/Illustration
1	Disconnect: <ul style="list-style-type: none"> • A2.X9 - T4.X3 • A2.X10 - T4.X1 • A1.X6 - A2.X11 • A1.X13 - A2.X12 • A2.X13 - G1/G2.X1 • A2.X14 - X111  Note This connector is used on controller with design front.	

Removing the manipulator signal (SMB) and motors power unit harness assembly

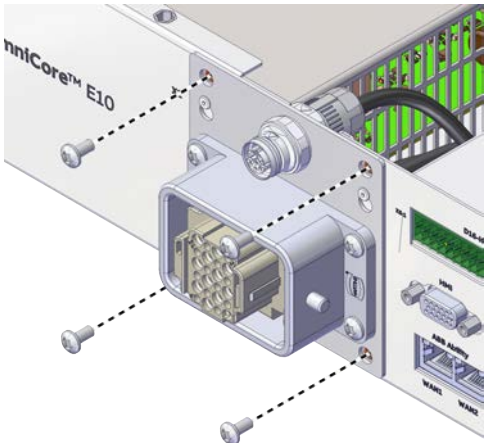
	Action	Note/Illustration
1	For SMB, disconnect: <ul style="list-style-type: none"> • X2- T4.X16 For motors power unit, disconnect: <ul style="list-style-type: none"> • X1 - T4.X7 • X1 - T4.X8 • X1 - T4.X9 • X1 - T4.X15 • One ground cable which connects to the front cabinet frame. 	
2	Pull the cable ties out from the locking holes.  Tip Take photos of the cable ties and locking holes before pulling out, to have as a reference when refitting the cable ties.	
3	Remove the attachment screws on the front panel.	 <p>xx2100001340</p>

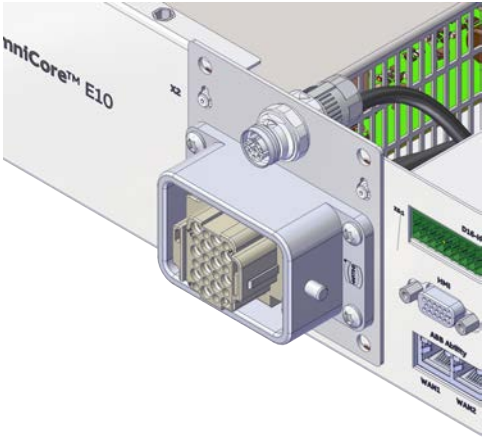
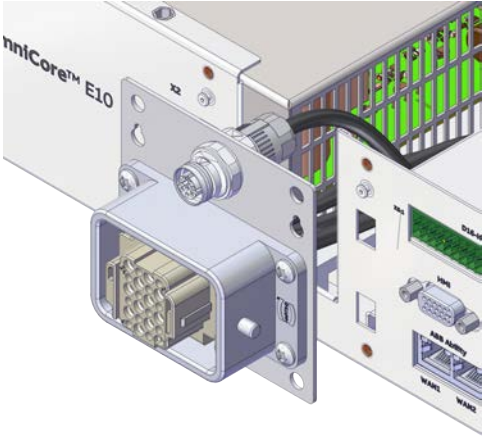

Continues on next page

5.3.1 Replacing the manipulator signal (SMB) and motors power unit harness assembly
Continued

	Action	Note/Illustration
4	Slide the harness assembly a little up to release it from the front panel.	 <p>xx2100001341</p>
5	Take the harness assembly out.	 <p>xx2100001342</p>

Refitting the manipulator signal (SMB) and motors power unit harness assembly

Refitting the manipulator signal (SMB) and motors power unit harness assembly

	Action	Note/Illustration
1	 <p>DANGER</p> <p>Before doing any work inside the cabinet, disconnect the mains power. For more information, see Electrical safety on page 30.</p>	
2	 <p>ELECTROSTATIC DISCHARGE (ESD)</p> <p>The unit is sensitive to ESD. Before handling the unit read the safety information in section The unit is sensitive to ESD on page 43.</p>	

Continues on next page

5 Repair

5.3.1 Replacing the manipulator signal (SMB) and motors power unit harness assembly

Continued

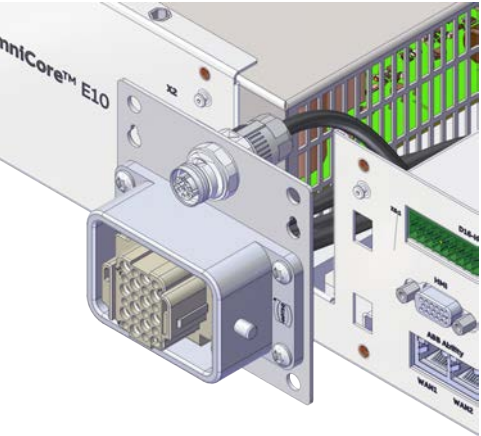
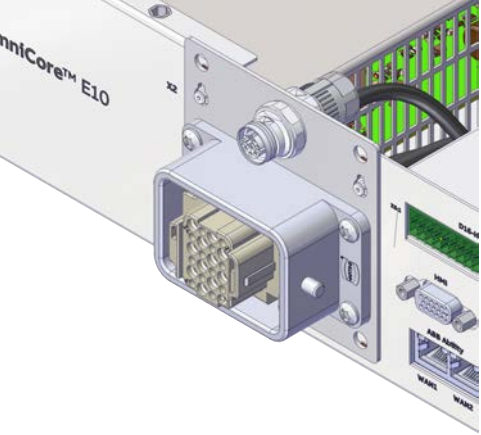
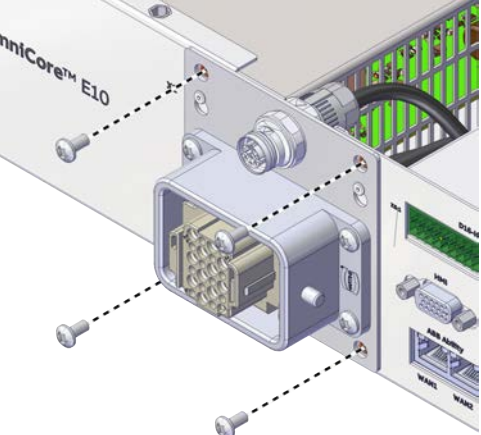



	Action	Note/Illustration
3	Refit the manipulator signal (SMB) and motors power unit harness assembly.	 <p data-bbox="927 768 1034 786">xx2100001342</p>
4	Slide the harness assembly a little down to lock it to the front panel.	 <p data-bbox="927 1281 1034 1299">xx2100001341</p>
5	Secure it with the attachment screws.	<p data-bbox="927 1337 1410 1397">Screws: Torx pan head screw M4x8 (4 pcs) Tightening torque: 1.7 Nm±10%.</p>  <p data-bbox="927 1854 1034 1872">xx2100001340</p>

Continues on next page

5.3.1 Replacing the manipulator signal (SMB) and motors power unit harness assembly
Continued

	Action	Note/Illustration
6	Insert the cable ties back to the locking holes.  Tip Refit the cable ties according to the photo.	

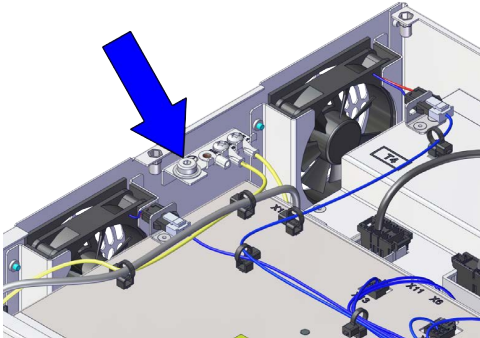
Reconnecting the connectors to the computer and logic unit

	Action	Note/Illustration
1	 DANGER Before doing any work inside the cabinet, disconnect the mains power. For more information, see Electrical safety on page 30 .	
2	 ELECTROSTATIC DISCHARGE (ESD) When handling the computer outside of the controller, use the wrist strap button located on the side of the computer.	Location of wrist strap button:  xx2100001295
3	Reconnect: <ul style="list-style-type: none"> • A2.X9 - T4.X3 • A2.X10 - T4.X1 • A1.X6 - A2.X11 • A1.X13 - A2.X12 • A2.X13 - G1/G2.X1 • A2.X14 - X111  Note This connector is used on controller with design front.	

Concluding procedure

	Action	Note/Illustration
1	Refit the top cover.	Refitting the controller cover on page 127 .
2	Perform the function tests to verify that the safety features work properly, see Function tests on page 116 .	

5 Repair

5.3.2 Replacing the incoming mains connector

5.3.2 Replacing the incoming mains connector

Location

The illustration shows the location of the incoming mains connector in the controller.



xx2100001328

Required spare parts



Note

The spare part numbers that are listed in the table can be out of date. See the latest spare parts of the OmniCore E10 via myABB Business Portal, www.abb.com/myABB.

Spare part	Article number	Note
Harness AC input with SW	3HAC075416-001	Harness-Mains connection
Connector AC power inlet	3HAC077706-001	Mating connector for Power inlet

Required tools and equipment

Equipment	Article number	Note
Standard toolkit	-	Content is defined in section Standard toolkit for controller on page 212 .
ESD protective wrist band	-	



Continues on next page

Required documents

Document	Article number	Note
Circuit diagram - OmniCore E10	3HAC076810-008	

Removing the incoming mains connector

Preparations

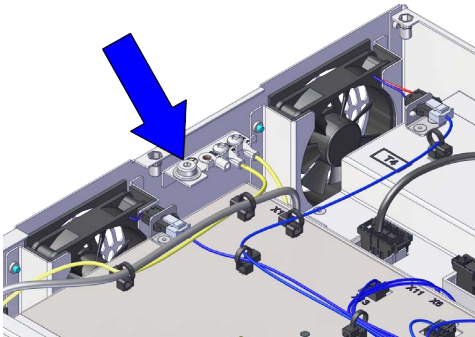
	Action	Note/Illustration
1	 DANGER Before doing any work inside the cabinet, disconnect the mains power. For more information, see Electrical safety on page 30 .	
2	 ELECTROSTATIC DISCHARGE (ESD) The unit is sensitive to ESD. Before handling the unit read the safety information in section The unit is sensitive to ESD on page 43 .	Location of wrist strap button:  xx2100001295
3	Remove the top cover of the controller.	Removing the controller top cover on page 126 .

Removing the incoming mains connector

	Action	Note/Illustration
1	Disconnect: <ul style="list-style-type: none"> • Q0 - A1.X1. • Two ground cables which connects to the left cabinet frame. 	
2	Pull the cable ties out from the locking holes.  Tip Take photos of the cable ties and locking holes before pulling out, to have as a reference when refitting the cable ties.	

Continues on next page

5 Repair

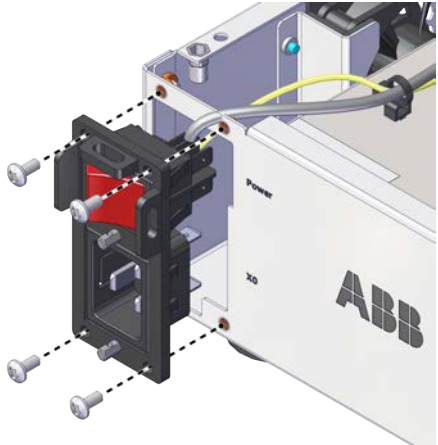

5.3.2 Replacing the incoming mains connector

Continued

	Action	Note/Illustration
3	Remove the attachment screws.	 <p data-bbox="924 768 1031 786">xx2100001339</p>
4	Take out the incoming mains connector.	

Refitting the incoming mains connector

Refitting the incoming mains connector

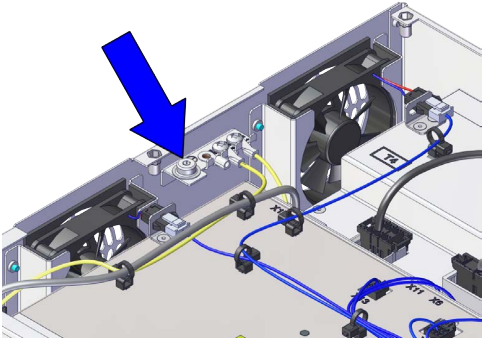
	Action	Note/Illustration
1	 <p data-bbox="563 1081 671 1104">DANGER</p> <p data-bbox="469 1144 911 1249">Before doing any work inside the cabinet, disconnect the mains power. For more information, see Electrical safety on page 30.</p>	
2	 <p data-bbox="563 1305 911 1357">ELECTROSTATIC DISCHARGE (ESD)</p> <p data-bbox="469 1384 911 1487">The unit is sensitive to ESD. Before handling the unit read the safety information in section The unit is sensitive to ESD on page 43.</p>	<p data-bbox="924 1283 1257 1305">Location of wrist strap button:</p>  <p data-bbox="924 1675 1031 1693">xx2100001295</p>
3	Insert the incoming mains connector into the front panel of the cabinet.	

Continues on next page

5.3.2 Replacing the incoming mains connector

Continued

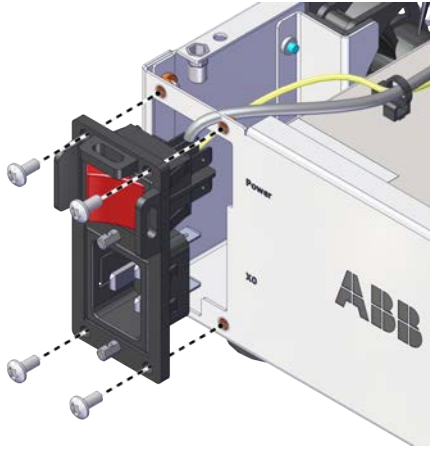
	Action	Note/Illustration
4	Secure it with the screws.	<p>Screws: Torx pan head screw M4x8 (4 pcs) Tightening torque: 1.7 Nm±10%.</p>  <p>xx2100001339</p>
5	Reconnect: <ul style="list-style-type: none"> • Q0 - A1.X1. • Two ground cables which connects to the left cabinet frame. 	

Concluding procedure

	Action	Note/Illustration
1	Refit the top cover.	Refitting the controller cover on page 127.
2	Perform the function tests to verify that the safety features work properly, see Function tests on page 116.	

5 Repair

5.4.1 Replacing the power cable and power cable cover

5.4 Replacing parts on the FlexPendant

5.4.1 Replacing the power cable and power cable cover

Location

The illustration shows the location of the power cable, power cable gasket, and power cable cover in the FlexPendant.

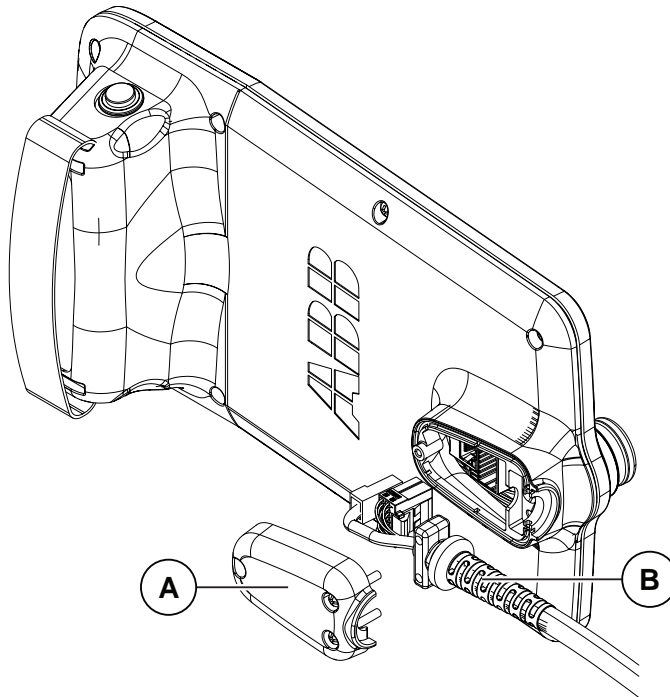

xx1800001154

A	Power cable cover
B	Power cable

Required spare parts



Note

The spare part numbers that are listed in the table can be out of date. See the latest spare parts of the OmniCore E10 via myABB Business Portal, www.abb.com/myABB.

Spare part	Article number	Note
FlexPendant	3HAC086996-001	DSQC3124
Power cable cover	3HAC065401-001	
FlexPendant power cable 3 m	3HAC064448-002	
FlexPendant power cable 10 m	3HAC064448-001	

Continues on next page

5.4.1 Replacing the power cable and power cable cover

Continued

Required tools and equipment

Equipment	Article number	Note
Standard toolkit	-	Content is defined in section Standard toolkit for controller on page 212 .
ESD protective wrist band	-	

Required documents

Document	Article number	Note
Circuit diagram - OmniCore E10	3HAC076810-008	

Removing the power cable and power cable cover

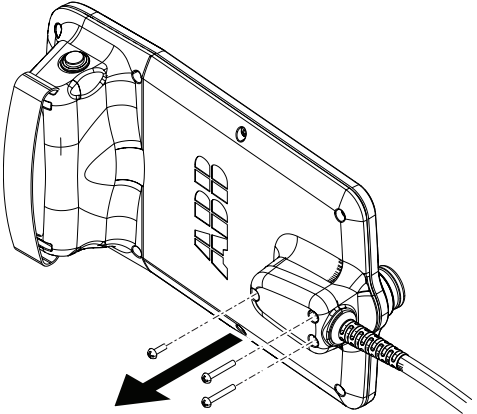
	Action	Note/Illustration
1	 ELECTROSTATIC DISCHARGE (ESD) The unit is sensitive to ESD. Before handling the unit read the safety information in section The unit is sensitive to ESD on page 43 .	
2	Disconnect the FlexPendant from the controller.	
3	Remove the attachment screws for the power cable cover.	 <p>xx1800001189</p>

Continues on next page

5 Repair

5.4.1 Replacing the power cable and power cable cover

Continued

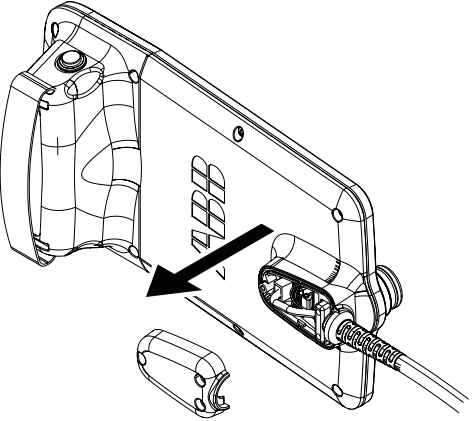
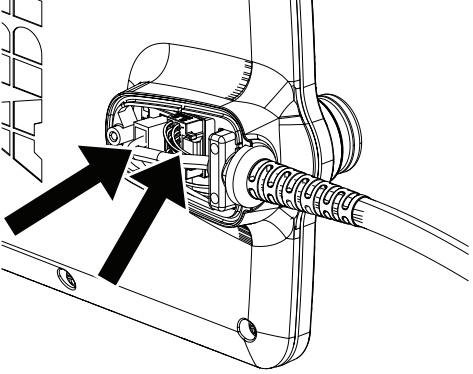
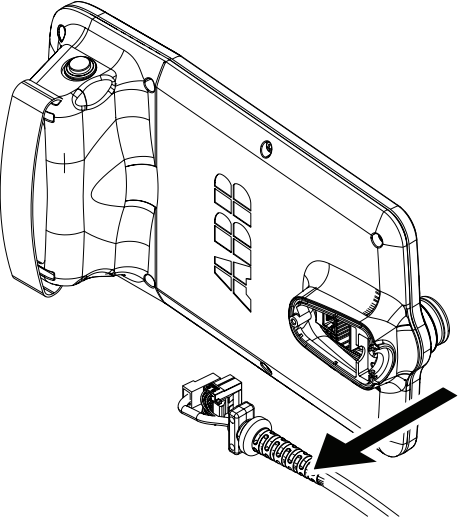
	Action	Note/Illustration
4	Remove the power cable cover.	 <p>xx1800001190</p>
5	Disconnect two connectors to the FlexPendant.	 <p>xx1800001748</p>
6	Remove the power cable.	 <p>xx1800001192</p>

Continues on next page

Refitting the power cable and power cable cover

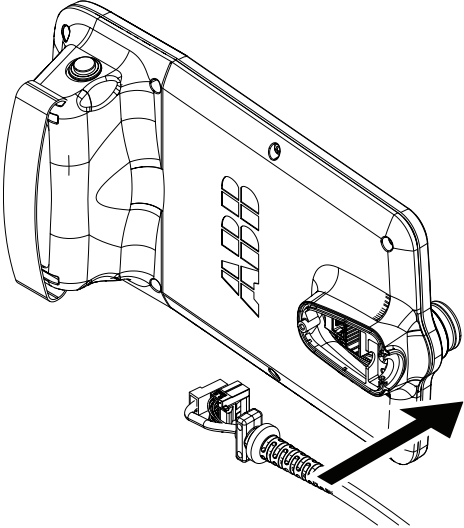
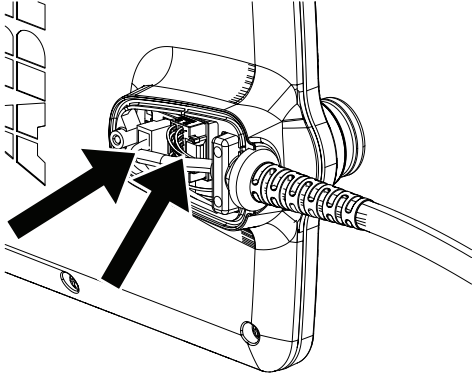
	Action	Note/Illustration
1	 <p>ELECTROSTATIC DISCHARGE (ESD)</p> <p>The unit is sensitive to ESD. Before handling the unit read the safety information in section <i>The unit is sensitive to ESD on page 43</i>.</p>	
2	<p>Refit the power cable.</p>	 <p>xx1800001193</p>
3	<p>Reconnect the power cable to the Flex-Pendant.</p>	 <p>xx1800001748</p>

Continues on next page

5 Repair

5.4.1 Replacing the power cable and power cable cover

Continued

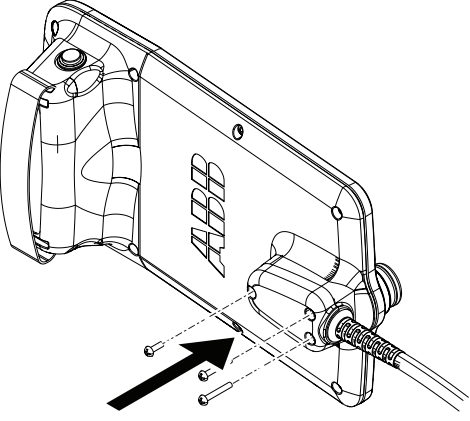
	Action	Note/Illustration
4	Refit the power cable cover and tighten the screws.	<p data-bbox="927 320 1398 344">Screws: Torx pan head screw M4x8 (3 pcs)</p>  <p data-bbox="927 770 1031 790">xx1800001196</p>
5	Perform the function tests to verify that the safety features work properly, see Function tests on page 116 .	

5.4.2 Replacing the joystick protection

Location

The illustration shows the location of the joystick protection on the FlexPendant.

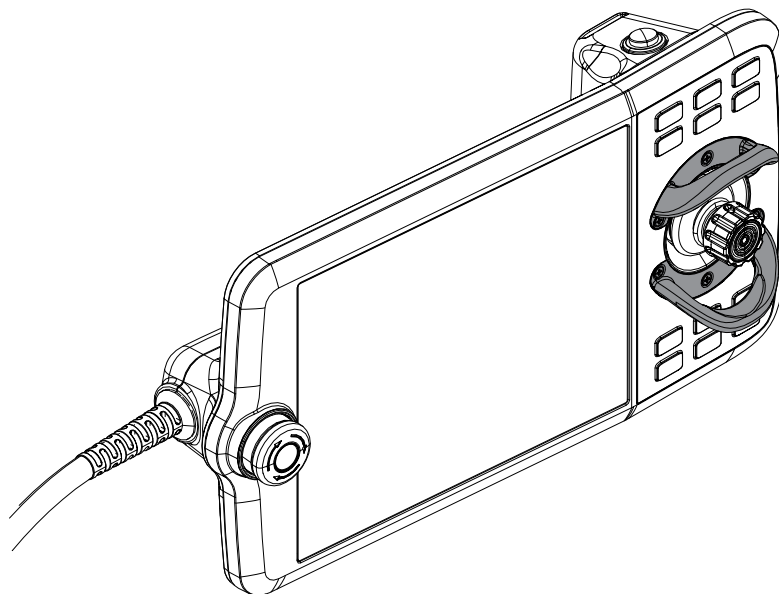

xx1800001197

Required spare parts



Note

The spare part numbers that are listed in the table can be out of date. See the latest spare parts of the OmniCore E10 via myABB Business Portal, www.abb.com/myABB.

Spare part	Article number	Note
Joystick guard	3HAC065408-001	

Required tools and equipment

Equipment	Article number	Note
Standard toolkit	-	Content is defined in section Standard toolkit for controller on page 212 .

Required documents

Document	Article number	Note
<i>Circuit diagram - OmniCore E10</i>	3HAC076810-008	

Continues on next page

5 Repair

5.4.2 Replacing the joystick protection

Continued

Removing the joystick protection

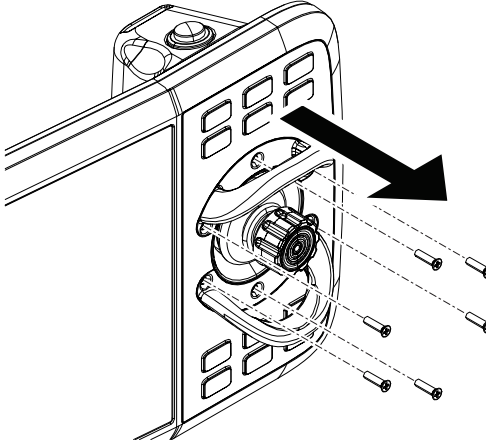
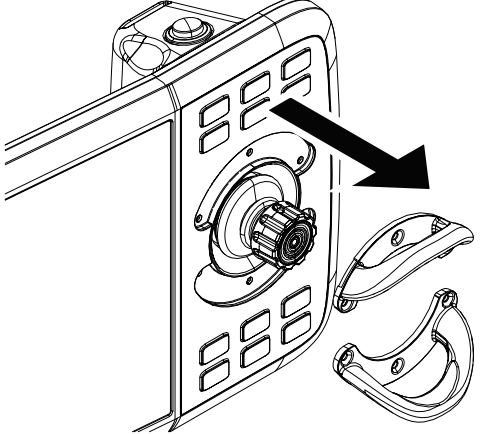
	Action	Note/Illustration
1	 ELECTROSTATIC DISCHARGE (ESD) The unit is sensitive to ESD. Before handling the unit read the safety information in section <i>The unit is sensitive to ESD on page 43</i> .	
2	Disconnect the FlexPendant from the controller.	
3	Remove the attachment screws.	 xx1800001198
4	Remove the joystick protection.	 xx1800001199

Refitting the joystick protection

	Action	Note/Illustration
1	 ELECTROSTATIC DISCHARGE (ESD) The unit is sensitive to ESD. Before handling the unit read the safety information in section <i>The unit is sensitive to ESD on page 43</i> .	

Continues on next page

5.4.2 Replacing the joystick protection
Continued

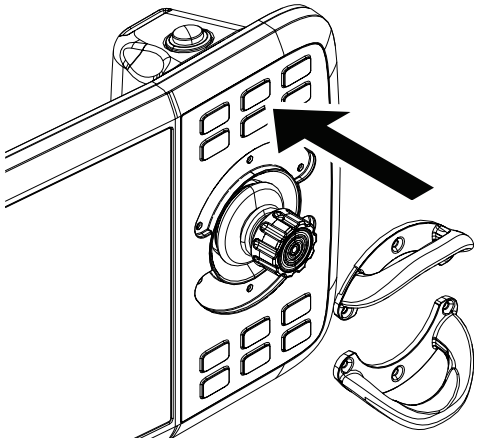
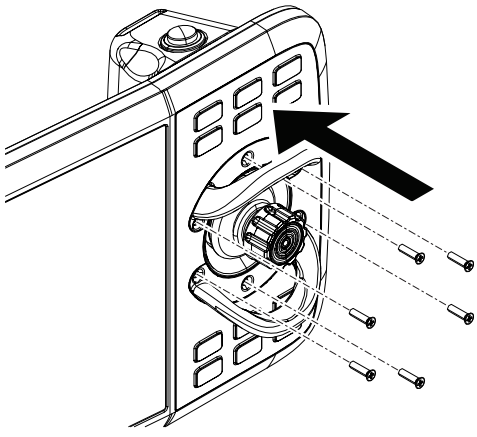
	Action	Note/Illustration
2	Refit the joystick protection.	 <p>xx1800001200</p>
3	Secure the screws.	 <p>xx1800001206</p> <p>Countersunk head screw: ST2.9 X 10 (6 pcs)</p>

5 Repair

5.4.3 Replacing the fasten strip

5.4.3 Replacing the fasten strip

Location

The illustration shows the location of the fasten strip on the FlexPendant.

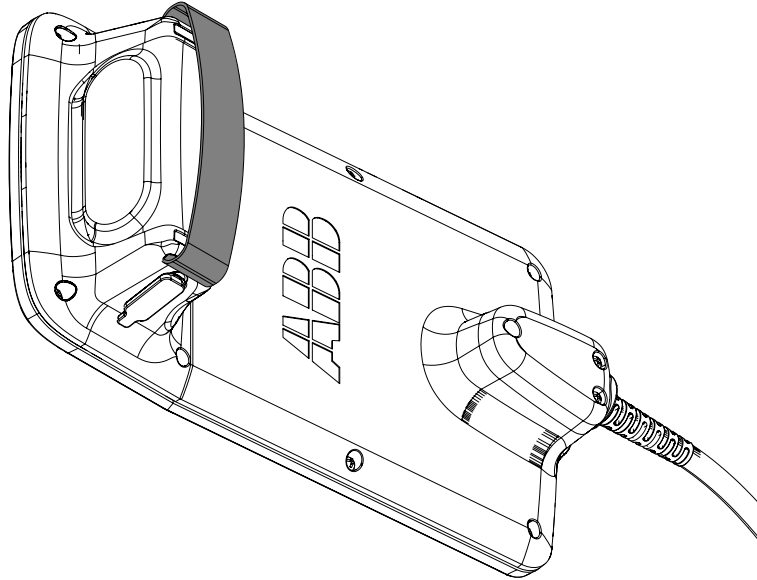

xx1900000771

Required spare parts



Note

The spare part numbers that are listed in the table can be out of date. See the latest spare parts of the OmniCore E10 via myABB Business Portal, www.abb.com/myABB.

Spare part	Article number	Note
Fasten strip	3HAC065419-001	

Replacing the fasten strip

	Action	Note/Illustration
1	Open the velcro on the fasten strip.	
2	Take the fasten strip out from the holes.	
3	Insert the new fasten strip into the holes one by one.	
4	Secure the velcro in a suitable length.	

6 Troubleshooting

6.1 Introduction to troubleshooting

Introduction

The product manual and the circuit diagram contains information that can be good when troubleshooting.

For OmniCore, all event logs from the software can be seen on the FlexPendant, or in *Technical reference manual - Event logs for RobotWare 7*.

Make sure to read through the section [Safety on page 15](#) before starting.

Troubleshooting strategies

- 1 Isolate the fault to pinpoint the cause of the problem from consequential problems.
- 2 Divide the fault chain in two.
- 3 Check communication parameters and cables.
- 4 Check that the software version is compatible with the hardware.

Work systematically

- 1 Take a look around to make sure that all screws, connectors, and cables are secured, and that the robot and other parts are clean, not damaged, and correctly fitted.
- 2 Replace one thing at a time.
- 3 Do not replace units randomly.
- 4 Make sure that there are no loose screws, turnings, or other unexpected parts remaining after work has been performed.
- 5 When the work is completed, verify that the safety functions are working as intended.

Keep a track of history

- Make a historical fault log to keep track of problems over time.
- Consult those working with the robot when the problem occurred.

Basic scenarios

What to look for during troubleshooting depends on when the fault occurred. Was the robot recently installed or was it recently repaired? The following table gives hints on what to look for in specific situations.

The robot has recently been installed	Check: <ul style="list-style-type: none"> • the configuration files • connectors • options and their configuration • changes in the robot working space/movements.
---------------------------------------	--

Continues on next page

6 Troubleshooting

6.1 Introduction to troubleshooting

Continued

The robot has recently been repaired	Check: <ul style="list-style-type: none">• all connections to the replaced part• power supplies• that the correct part has been fitted• the last repair documents.
The robot recently had a software upgrade	Check: <ul style="list-style-type: none">• software versions• compatibilities between hardware and software• options and their configuration
The robot has recently been moved from one site to another (an already working robot)	Check: <ul style="list-style-type: none">• connections• software versions

6.2 Troubleshooting fault symptoms

Fault symptoms described in this manual

This manual describes how to troubleshoot the following fault symptoms:

- *No LEDs are lit on the controller on page 176*
- *Start-up failure on page 179*
- *Problem releasing the robot brakes on page 181*
- *Problem starting or connecting the FlexPendant on page 184*
- *Problem using the joystick on page 188*
- *Controller fails to start on page 189*
- *Reflashing firmware failure on page 190*
- *Inconsistent path accuracy on page 191*
- *Controller is overheated on page 193*

Continues on next page

6 Troubleshooting

6.2.1 No LEDs are lit on the controller

6.2.1 No LEDs are lit on the controller

Description

No LEDs at all are lit in the controller.

Required test equipment

Equipment needed for troubleshooting:

Equipment	Note
Multimeter	
Insulating gloves	

Preparations

	Action
1	Make sure that the controller is switched on. Wait 30 s - 1 min to enable start-up sequence.
2	Check the FlexPendant for errors and warnings.
	 DANGER Troubleshooting on the controller while powered on must be performed by personnel trained by ABB or by ABB field engineers.

Recommended working procedure

If no LEDs are lit on the controller during start-up, use this procedure to troubleshoot what might cause the problem.

Look at the following block diagram to understand how power is connected from incoming and forward.

Block diagram

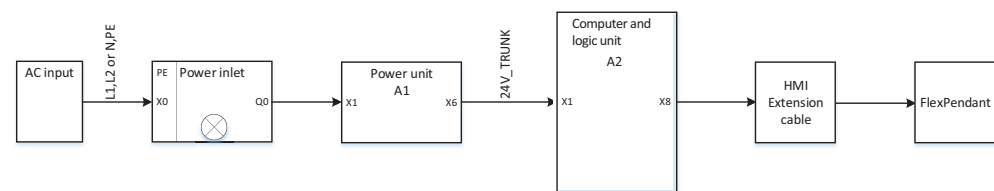

xx2100001552

Continues on next page

Troubleshooting flowchart

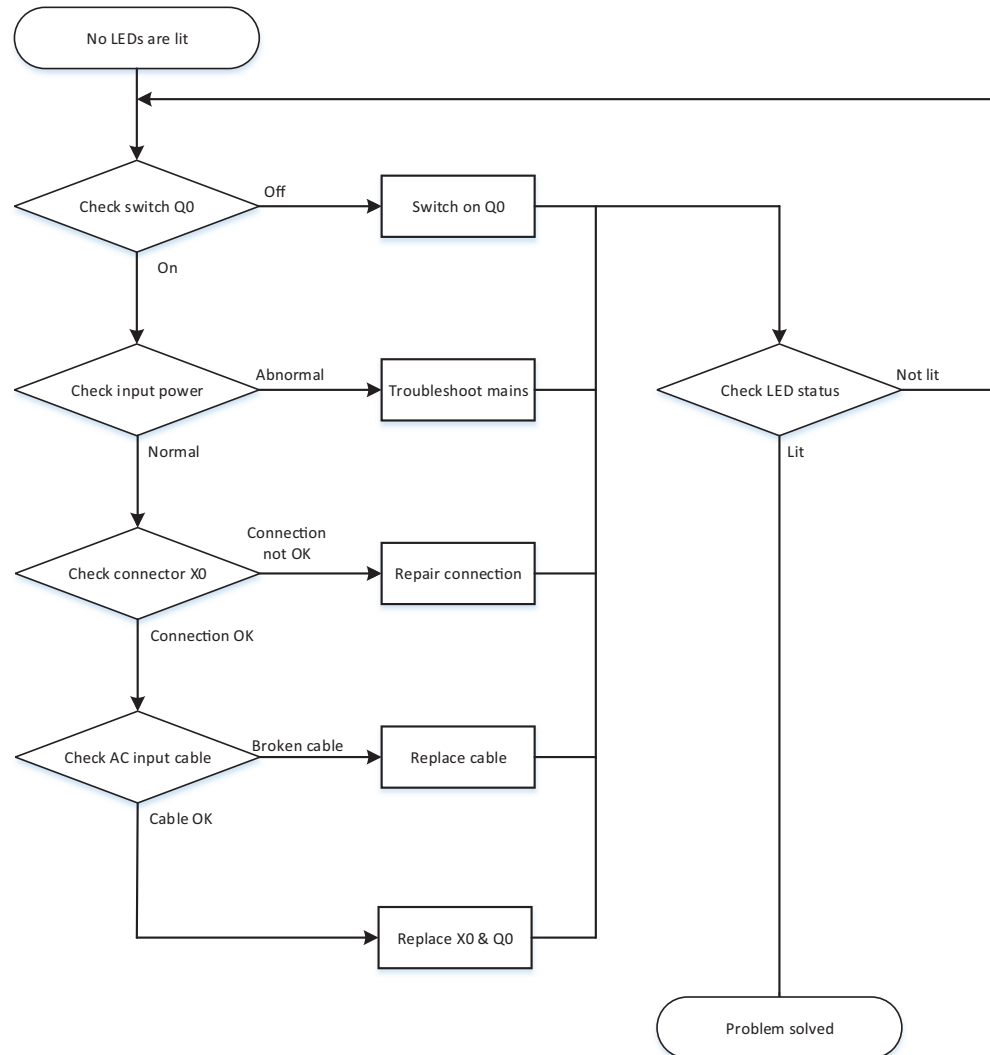

xx2100001553

Detailed working procedure

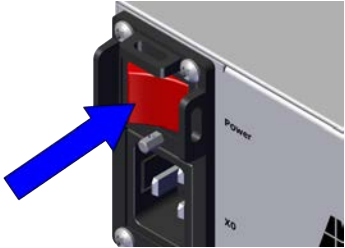
	Action	Note
1	Make sure that the power inlet switch (Q0) has been switched on.	 <p>xx2100001554</p>
2	Make sure that the system is supplied with power. <ul style="list-style-type: none"> Make sure that the RCD and circuit breaker/ fuse (if used) are closed. Measure incoming mains voltage and make sure the voltage is within the normal range. 	Use a multimeter and insulating gloves. If incoming mains is not ok, the problem is not in the robot controller. Troubleshoot incoming mains.

Continues on next page

6 Troubleshooting

6.2.1 No LEDs are lit on the controller

Continued

	Action	Note
3	<p>Check that the mains connection (X0) is properly connected.</p> <p> Tip</p> <p>For more details, see <i>Circuit diagram - OmniCore E10</i>.</p>	
4	<p>Check that the AC input cable is properly connected.</p>	<ul style="list-style-type: none">• If abnormal, fix the connection.• If normal, replace the power inlet. See Replacing the incoming mains connector on page 160.

6.2.2 Start-up failure

Description

The following are possible symptoms of a start-up failure:

- 1 The LEDs are not lit on some units.
- 2 Unable to load the system software.

Required test equipment

Equipment needed for troubleshooting:

Equipment	Note
Multimeter	
Insulating gloves	
<i>Circuit diagram - OmniCore E10</i>	<i>3HAC076810-008</i>

Preparations

Action	
1	Make sure that the controller is switched on. Wait 30 s - 1 min to enable start-up sequence.
2	Check the FlexPendant for errors and warnings.
	 DANGER Troubleshooting on the controller while powered on must be performed by personnel trained by ABB or by ABB field engineers.

Detailed working procedure

	Action	Note
1	Look at the computer and logic unit status LED Computer.	For more details about the LEDs, see Troubleshooting the computer and logic unit on page 202 .
2	Look at the power unit status LED.	For more details about the LEDs, see Troubleshooting the power unit on page 199 .
3	Look at the drive unit status LED.	For more details about the LEDs, see Troubleshooting the drive unit on page 196 .
4	If the problem remains, contact ABB.	



Tip

For more details, see *Circuit diagram - OmniCore E10*.

6 Troubleshooting

6.2.3 System update failure

6.2.3 System update failure

Description

In certain scenarios, such as removing or adding certain optional features or major upgrades of installed software products versions, the previous backup may be incompatible with the newly re-configured system. Automatically reloading backup can therefore fail, resulting in system failure state after the update.

For more information about system update, see *Operating manual - Integrator's guide OmniCore*.

Recommended working procedure

To remove system failure resulting from system updates, there are two main strategies:

- A Go forward with the new system configuration and correct the errors, see [New system configuration on page 180](#).
- B Rollback all changes in the system and bring the system to the same state as it was before the update, see [Rollback all changes in the system on page 180](#).

New system configuration

- 1 Reset the RobotWare system.
The RAPID program and system parameters will be removed, and the system will be set to default state, but without system failure.
- 2 Re-implement your programs or configuration changes, or
- 3 Selectively load contents from the previous system backup and correct possible errors when loading.

Rollback all changes in the system

The previous system state can be restored through the RobotWare Installation Utilities in one of the following ways:

- 1 Restore all installed software, user and system internal data with a selected snapshot (backup copy) of the previous system state. This is the simplest way.
- 2 Perform a complete re-installation of the RobotWare system using RobotWare Installation Utilities, start the RobotWare system and then reload the previous backup.

6.2.4 Problem releasing the robot brakes

Description

When starting robot operation or jogging the robot, the internal robot brakes must release in order to allow movement.

Required test equipment

Equipment needed for troubleshooting:

Equipment	Note
Multimeter	
Insulating gloves	
Circuit diagram - OmniCore E10	3HAC076810-008

Preparations

	Action
1	Make sure that the controller is switched on. Wait 30 s - 1 min to enable start-up sequence.
2	Check the FlexPendant for errors and warnings.
	 DANGER Troubleshooting on the controller while powered on must be performed by personnel trained by ABB or by ABB field engineers.

Recommended working procedure

If the brakes do not release, no robot movement is possible and a number of error log messages can occur. Use this procedure to troubleshoot what might cause the problem.

Look at the following block diagram to understand how power is connected from incoming and forward.

Block diagram

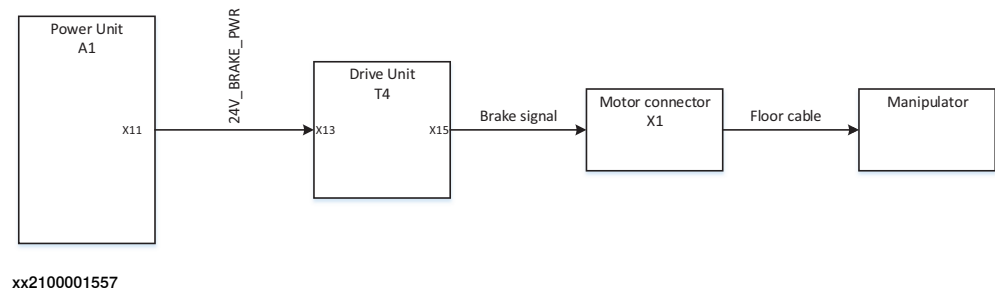

Continues on next page

6 Troubleshooting

6.2.4 Problem releasing the robot brakes

Continued

Troubleshooting flowchart

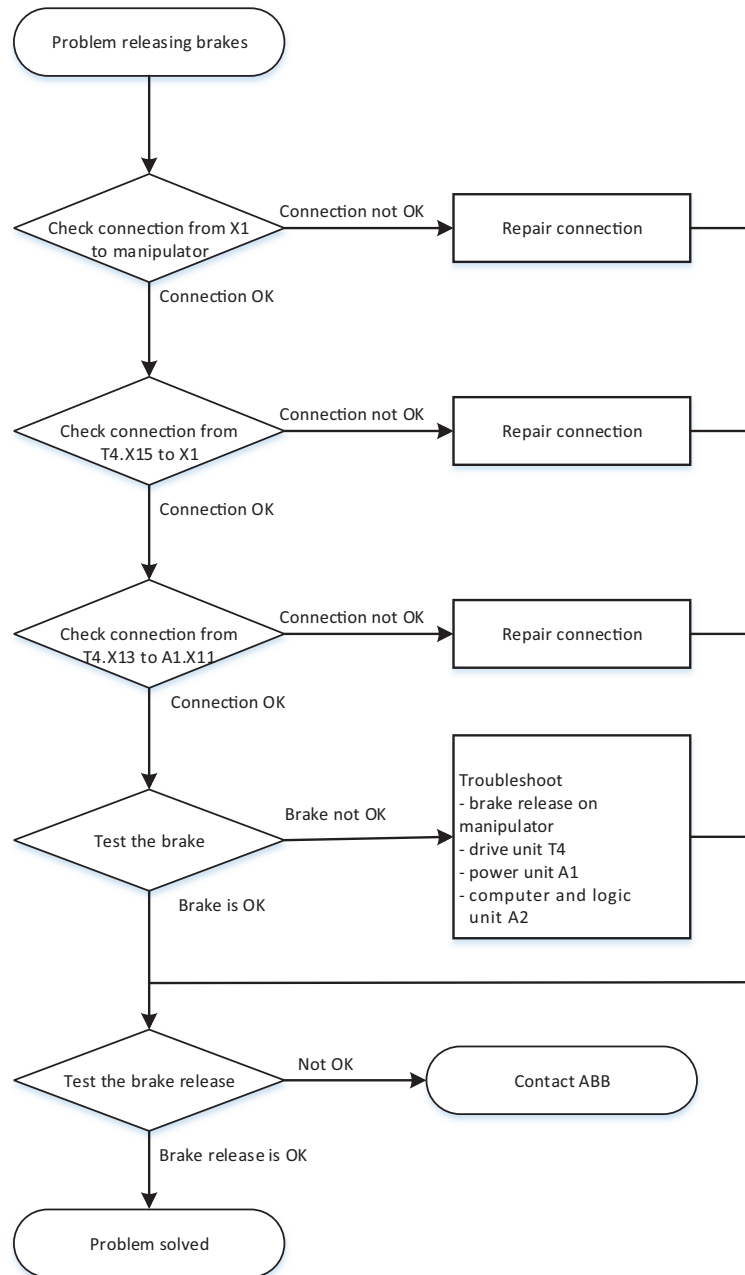

xx2100001558

Continues on next page

Detailed working procedure

	Action	Note
1	<p>Check that the floor cable is connected from the manipulator to the motor connector X1. Visually inspect the cable for damage or extensive bending marks.</p> <p> Tip</p> <p>For more details, see <i>Circuit diagram - OmniCore E10</i>.</p>	<ul style="list-style-type: none"> • If the cable is damaged, replace to a new cable and go to step 5. • If the cable is not connected, repair the connection and go to step 5. • If the cable is ok, go to the next step.
2	<p>Check that the connection from the main drive unit to the motor connector is ok:</p> <ul style="list-style-type: none"> • T4.X15 - X1. 	<ul style="list-style-type: none"> • If it is not, repair the connection and go to step 5. • If it is ok, go to the next step.
3	<p>Check that the connection from the main drive unit to the power unit is ok:</p> <ul style="list-style-type: none"> • T4.X13 - A1.X11 	<ul style="list-style-type: none"> • If it is not, repair the connection and go to step 5. • If it is ok, go to the next step.
4	<p>Try jogging the robot.</p>	<ul style="list-style-type: none"> • If it is not working properly, the brake release board on the manipulator might be broken. Contact your local ABB for more information. • If the brakes work normally, troubleshoot the computer and logic unit, and the power unit, one by one. If needed, replace faulty units. Go to step 5.
5	<p>Check that the brake release function is ok.</p>	<p>For more details on how to release the brakes, see the robot's product manual.</p> <ul style="list-style-type: none"> • If it is not ok, contact your local ABB.

6 Troubleshooting

6.2.5 Problem starting or connecting the FlexPendant

6.2.5 Problem starting or connecting the FlexPendant

Description

The FlexPendant is not responding, either completely or intermittently. No entries are possible, and no functions are available.



Note

If protective gloves are used, these must be compatible with touchscreens when using the FlexPendant.

The FlexPendant starts but does not display the main interface.

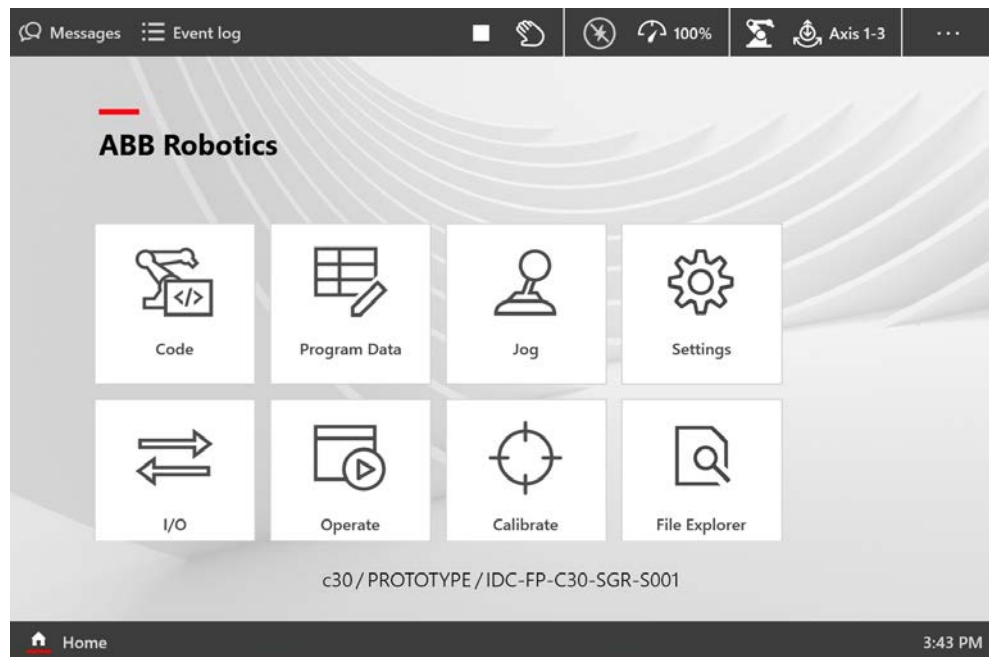

xx1900000917

Required test equipment

Equipment needed for troubleshooting:

Equipment	Note
Multimeter	
Insulating gloves	
Circuit diagram - OmniCore E10	3HAC076810-008

Preparations

	Action
1	Make sure that the controller is switched on. Wait 30 s - 1 min to enable start-up sequence.
2	Check the FlexPendant for errors and warnings.

Continues on next page

Action	
	<p>DANGER</p> <p>Troubleshooting on the controller while powered on must be performed by personnel trained by ABB or by ABB field engineers.</p>

Recommended working procedure

If the FlexPendant starts but does not display the main interface during the start-up, use this procedure to troubleshoot what might cause the problem.

Look at the following block diagram to understand how power is connected from incoming and forward.

Block diagram

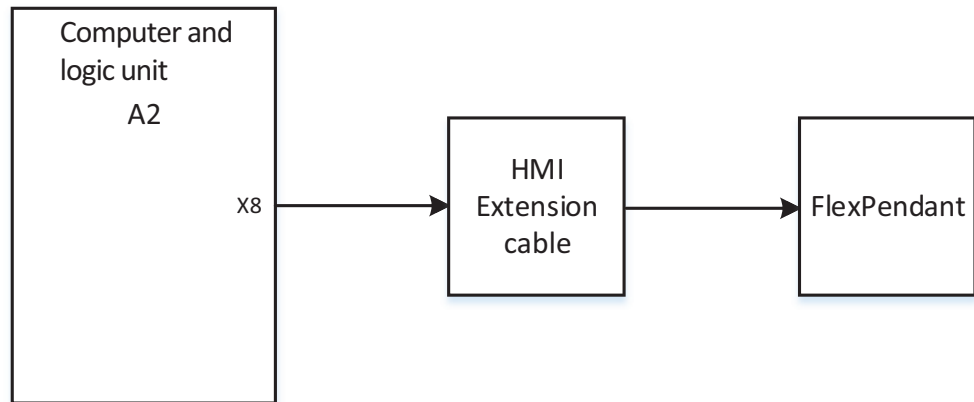

xx2100001555

Continues on next page

6 Troubleshooting

6.2.5 Problem starting or connecting the FlexPendant

Continued

Troubleshooting flowchart

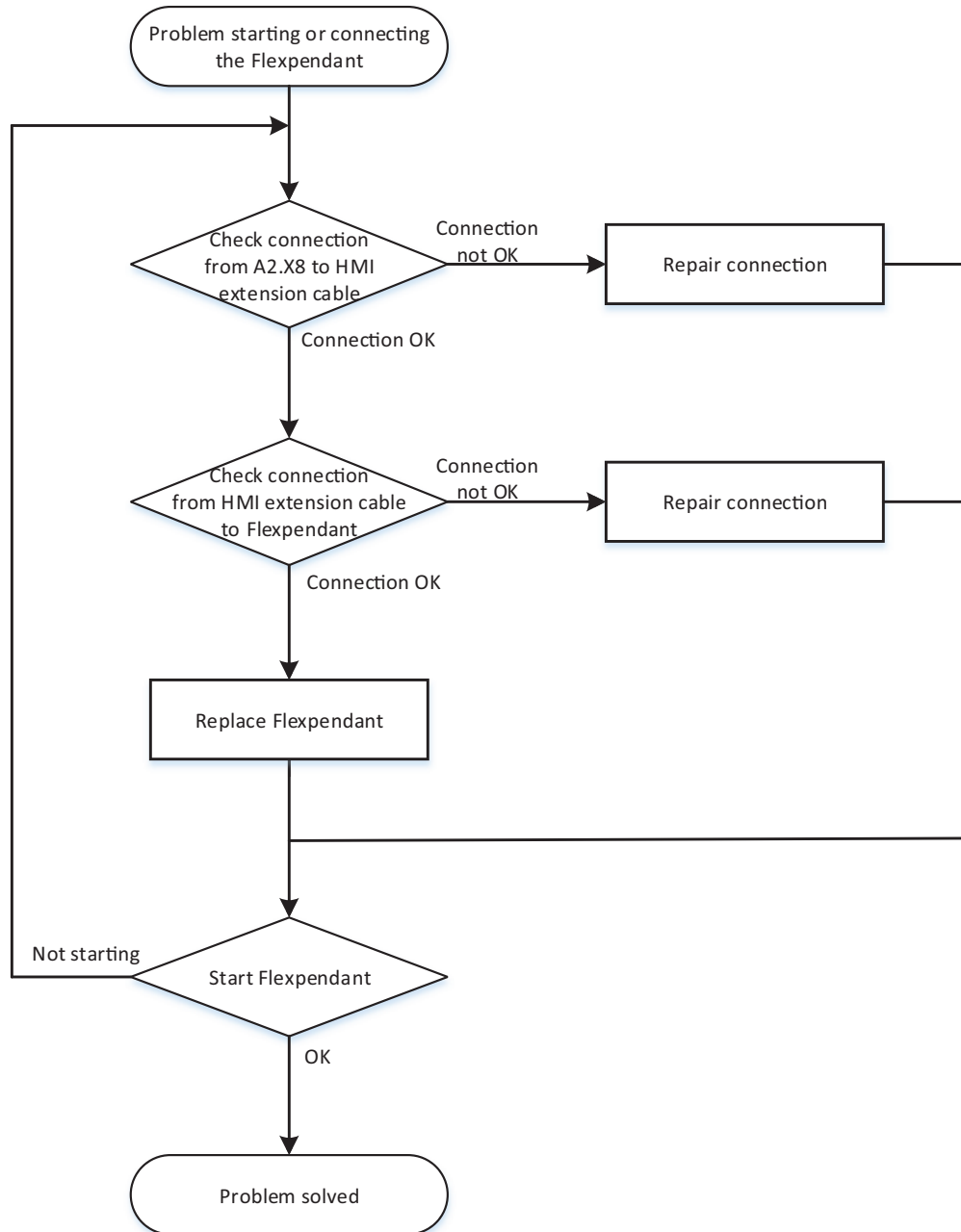

xx2100001556

Detailed working procedure

	Action	Note
1	Try resetting the FlexPendant using the reset button located next to the USB port.	See <i>Operating manual - OmniCore</i> .
2	Check that the extension cable is correctly connected to the controller through the HMI signal connector.	If it is not connected, repair the connection and go to step six. Check the pins in the connector. If it is ok, go to the next step.

Continues on next page

	Action	Note
3	Check that the FlexPendant cable is correctly connected to the extension cable.	If it is not connected, repair the connection and go to step six. Check the pins in the connector. If it is ok, go to the next step.
4	Check the FlexPendant cable for any damage.	<ul style="list-style-type: none"> • If damage is found, replace the FlexPendant cable and go to step six. • If it is ok, go to the next step.
5	If possible, test by connecting another FlexPendant. This is to eliminate the FlexPendant and cable as error sources; Test the FlexPendant with a different controller to eliminate the controller as error source.	
6	Check that the FlexPendant works normally.  Tip This is detailed in section Troubleshooting the FlexPendant on page 195 .	If it is not ok, contact your local ABB.

6 Troubleshooting

6.2.6 Problem using the joystick

6.2.6 Problem using the joystick

Description

The FlexPendant is started and responds when you push the buttons or tap on the touchscreen. However, the joystick does not work and no warnings or messages show up. It is therefore not possible to jog the robot.

Recommended working procedure

	Action	Information
1	Make sure that the joystick lock is not activated.	See <i>Operating manual - OmniCore</i> .
2	Make sure the controller is in manual mode.	
3	Make sure the FlexPendant is connected correctly to the controller.	
4	Press the reset button located next to the USB port on the back of the FlexPendant.  Note The reset button only resets the FlexPendant, not the system on the controller.	If the joystick is still not working, then replace the FlexPendant.

6.2.7 Controller fails to start

Description

If the controller fails to start, the FlexPendant is not operational.

Function description

The robot controller always runs in one of the following two modes:

- Normal operation mode (a user-created system is selected to run)
- RobotWare Installation Utilities mode (advanced maintenance mode)

In rare occasions, a serious error (in the software or the configuration of the installed system), may prevent the controller from starting properly in the normal operation mode. A typical case is when a controller is restarted after a network configuration change, causing the controller to be non-responsive from FlexPendant, RobotStudio, or FTP. To restore the robot controller from this situation, the controller can be forced to start in RobotWare Installation Utilities mode.

Forcing startup of the RobotWare Installation Utilities mode

Repeat the following action two times in a row:

- 1 Turn on the main power switch.
- 2 Wait for approximately 15 seconds.



Note

The Computer LED should be in flashing red state.

- 3 Turn off the main power switch.

In the next startup (third time), the installed system is de-selected and the RobotWare Installation Utilities mode is started.

This has no effect if the controller is already in RobotWare Installation Utilities mode.



Note

Force starting the RobotWare Installation Utilities mode will not affect the files in the directories belonging to the installed system.

See also [Troubleshooting the computer and logic unit on page 202](#).

How to install systems is described in *Operating manual - Integrator's guide OmniCore*.

6 Troubleshooting

6.2.8 Reflashing firmware failure

6.2.8 Reflashing firmware failure

Description

When reflashing firmware, the automatic process can fail which will stop the system. A message is generated in the event log.

This fault usually occurs due to a lack of compatibility between hardware and software.

Recommended working procedure

If the controller stops with a message about firmware failure, use this procedure to troubleshoot what might cause the problem.

	Action	Note
1	Read the message to see which unit has failed.	
2	If the relevant unit has been replaced recently, make sure that the versions of the old and the new unit are identical.	
3	Check the software versions.	
4	If RobotWare has been updated recently, make sure that the versions of the old and the new unit are identical.	
5	If the problem remains, contact your local ABB for information about which firmware version is compatible with your hardware.	

6.2.9 Inconsistent path accuracy

Description

The path of the robot TCP is not consistent. It varies from time to time, and is sometimes accompanied by noise emerging from bearings, gearboxes, or other locations.

Possible causes

The symptom can be caused by (the causes are listed in order of probability):

- Robot not calibrated correctly.
- Robot TCP not correctly defined.
- Parallel bar damaged (applies to robots fitted with parallel bars only).
- Mechanical joint between motor and gearbox damaged. This often causes noise to be emitted from the faulty motor.
- Bearings damaged or worn (especially if the path inconsistency is coupled with clicking or grinding noises from one or more bearings).
- The wrong robot type may be connected to the controller.
- The brakes may not be releasing correctly.

Recommended working procedure

The path accuracy depends on many factors. The following table describes the most common causes of problems with the path accuracy. Depending on your installation, the recommended working procedure is to work step by step, starting with the step that seems most plausible given your circumstances.

	Action	Note
1	Study the path of the robot in motion, to find if an external force, for example, an external cable package, is colliding with or restricting the movement of the robot.	Remove the obstacles.
2	In high temperature environments, the material in the robot can expand, thereby causing inconsistent path accuracy.	Improve the ventilation around the robot.
3	Make sure the robot tool and work object are correctly defined.	How to define these are described in <i>Operating manual - OmniCore</i> .
4	Check the positions of the revolution counters.	Update if required.
5	If required, re-calibrate the robot axes.	How to calibrate the robot is described in the product manual for the robot.
6	If you hear noise that has not been there before, locate the source to define if a motor or bearing is faulty. Study the path of the robot TCP to establish which axis, and thus which motor, may be faulty.	Replace the faulty motor, gearbox, or bearing as specified in the product manual for the robot.
7	Check the trueness of the parallel bar (applies to robots fitted with parallel bars only).	Replace the faulty parallel bar as specified in the product manual for the robot.

Continues on next page

6 Troubleshooting

6.2.9 Inconsistent path accuracy

Continued

	Action	Note
8	Make sure the correct robot type is connected as specified in the system.	Update the system with the correct robot type, see <i>Operating manual - Integrator's guide OmniCore</i> .
9	Make sure the robot brakes work properly.	Proceed as detailed in section Problem releasing the robot brakes on page 181 .
10	If applicable: Check the setting for the swivel.	The swivel has an in-built resistance that needs to be set in the system parameters.

6.2.10 Controller is overheated

Required test equipment

Equipment needed for troubleshooting:

Equipment	Note
Multimeter	
Insulating gloves	
Circuit diagram - OmniCore E10	3HAC076810-008

Preparations

	Action
1	Make sure that the controller is switched on. Wait 30 s - 1 min to enable start-up sequence.
2	Check the FlexPendant for errors and warnings.
	 DANGER Troubleshooting on the controller while powered on must be performed by personnel trained by ABB or by ABB field engineers.

Recommended working procedure

If the controller seems to be overheated, use this procedure to troubleshoot what might cause the problem.

Detailed working procedure

	Action	Note
1		
2	If the problem remains, troubleshoot the power unit and/or the drive unit.	See Troubleshooting the power unit on page 199 and Troubleshooting the drive unit on page 196 .

6 Troubleshooting

6.3.1 Troubleshooting LEDs in the controller

6.3 Troubleshooting units

6.3.1 Troubleshooting LEDs in the controller

Description

The controller features a number of indication LEDs, which provide important information for troubleshooting purposes. If no LEDs light up at all when switching the system on, troubleshoot as detailed in this section.

All LEDs on the respective units, and their significance, are described in the following sections.

Units with LEDs in the controller

Drive unit	Troubleshooting the drive unit on page 196
Power unit	Troubleshooting the power unit on page 199
Scalable I/O	Troubleshooting fieldbuses and I/O on page 201
Computer and logic unit	Troubleshooting the computer and logic unit on page 202

6.3.2 Troubleshooting the FlexPendant

Description

The FlexPendant communicates with the computer and logic unit. The FlexPendant is physically connected to the panel board. The cable contains the +24 V supply, two enabling device chains and emergency stop.

Procedure

The procedure below describes what to do if the FlexPendant does not work correctly.

	Action	Note
1	Try resetting the FlexPendant using the reset button located next to the USB port.	See <i>Operating manual - OmniCore</i> .
2	If the FlexPendant is not responding or does not operate correctly, see Problem starting or connecting the FlexPendant on page 184 .	 Note If protective gloves are used, these must be compatible with touchscreens when using the FlexPendant.
3	Check the cable for connections and integrity.	
4	Check the 24 V power supply.	
5	Read the error event log message and follow any instructions of references.	

For more information on the FlexPendant, see *Operating manual - OmniCore*.

6 Troubleshooting

6.3.3 Troubleshooting the drive unit

6.3.3 Troubleshooting the drive unit

Location

The illustration shows the location of the drive unit in the controller.

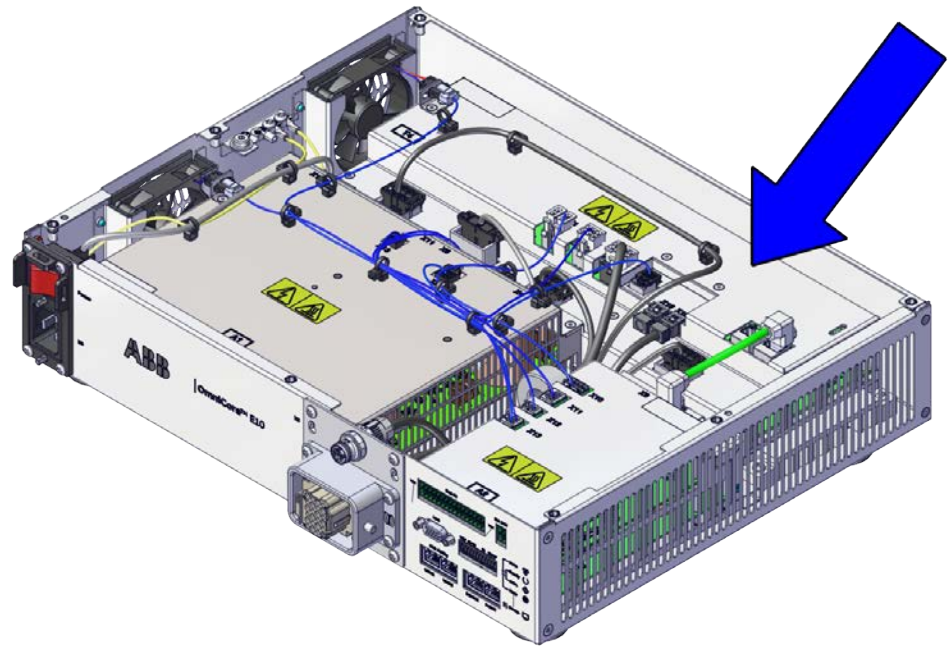

xx2100001323

Continues on next page

LEDs

The illustration below shows the indication LEDs on the drive unit.

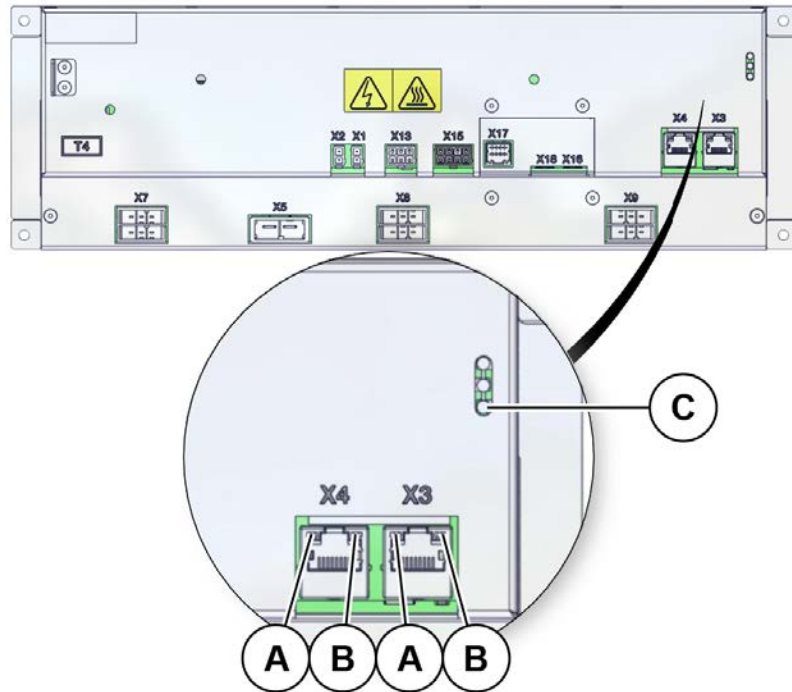

xx2100001560

A	Ethernet LEDs (yellow)
B	Ethernet LEDs (green)
C	Status LED

Description	Significance
Ethernet LEDs	Shows the status of Ethernet communication between the drive unit and the power unit. Green: <ul style="list-style-type: none"> Off: 10 Mbps data rate is selected. On: 100 Mbps data rate is selected. Yellow: <ul style="list-style-type: none"> Flashing: The two units are communicating on the Ethernet channel. Steady: A LAN link is established. Off: A LAN link is <i>not</i> established.

Continues on next page

6 Troubleshooting

6.3.3 Troubleshooting the drive unit

Continued

Description	Significance
Drive unit status LED	<p>The status indicator LED can be used to identify the following status during startup/power on:</p> <ol style="list-style-type: none"><li data-bbox="647 367 1187 396">1 Red, steady: Default when power is available.<li data-bbox="647 400 1404 456">2 Red, flashing: Power is on, self-test is ongoing, operating system is loading.<li data-bbox="647 461 1404 517">3 Green, flashing: Application is loaded and waiting for communication.<li data-bbox="647 521 1123 551">4 Green, steady: Drive unit is operational. <p>If the LED does not turn steady green after 30-60 sec, the status indicator LED can be used to identify the following issues:</p> <ul style="list-style-type: none"><li data-bbox="647 609 1166 638">• No color: Power to the drive unit is missing.<li data-bbox="647 642 979 672">• Red, steady: Internal error.<li data-bbox="647 676 1214 705">• Red, flashing: Firmware error or self-test failure.<li data-bbox="647 710 1318 739">• Green, flashing: Communication error to another module.

6.3.4 Troubleshooting the power unit

Location

The illustration below shows the location of the power unit in the controller.

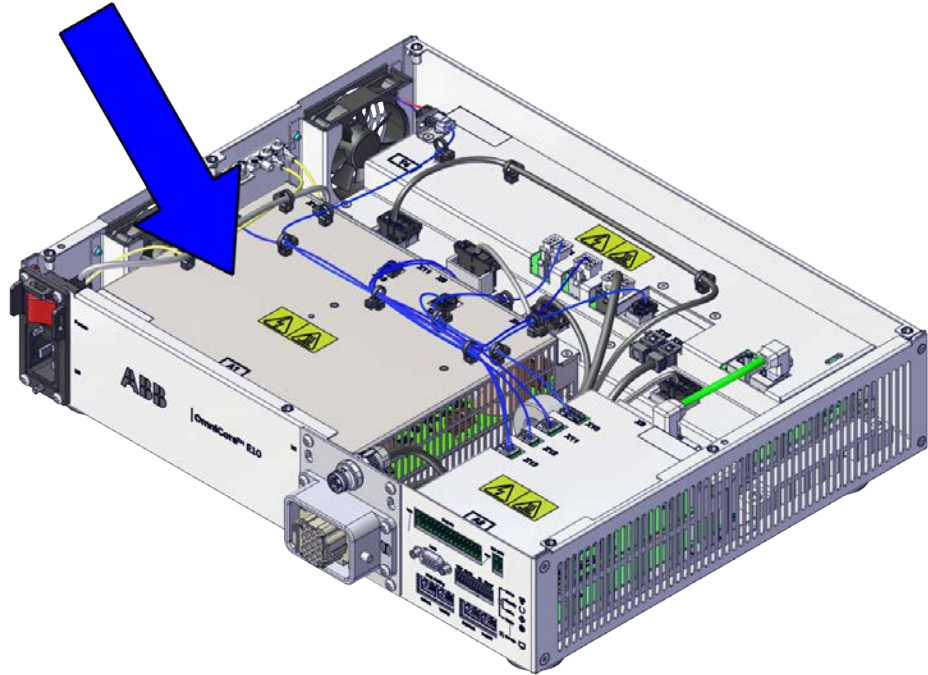

xx2100001324

LEDs

The illustration below shows the LEDs on the power unit.

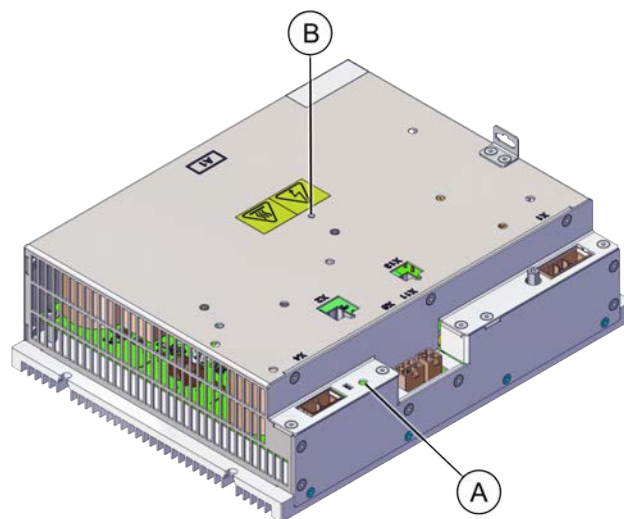

xx2100001561

Continues on next page

6 Troubleshooting

6.3.4 Troubleshooting the power unit

Continued

A	High voltage warning
B	Status LED
Description	
Power unit status LED	<p>The status indicator LED can be used to identify the following status during startup/power on:</p> <ol style="list-style-type: none">1 Red, steady: Default when power is available.2 Red, flashing: Power is on, self-test is ongoing, operating system is loading.3 Green, flashing: Application is loaded and initializing.4 Green, steady: Power unit is operational. <p>If the LED does not turn steady green after 30-60sec, then the status indicator LED can be used to identify the following issues:</p> <ul style="list-style-type: none">• No color: Power to the power unit is missing.• Red, steady: Internal error.• Red, flashing: Firmware error or self-test failure.
High voltage warning	<ul style="list-style-type: none">• No color: Voltage between DC+ - DC- \leq 60 VDC• Red: Voltage between DC+ - DC- $>$ 60 VDC

6.3.5 Troubleshooting fieldbuses and I/O

Further information

Information about how to troubleshoot the fieldbuses and I/O units can be found in the manual for the respective fieldbus or I/O unit. See [References on page 10](#).

6 Troubleshooting

6.3.6 Troubleshooting the computer and logic unit

6.3.6 Troubleshooting the computer and logic unit

Location

The illustration shows the location of the computer and logic unit in the controller.

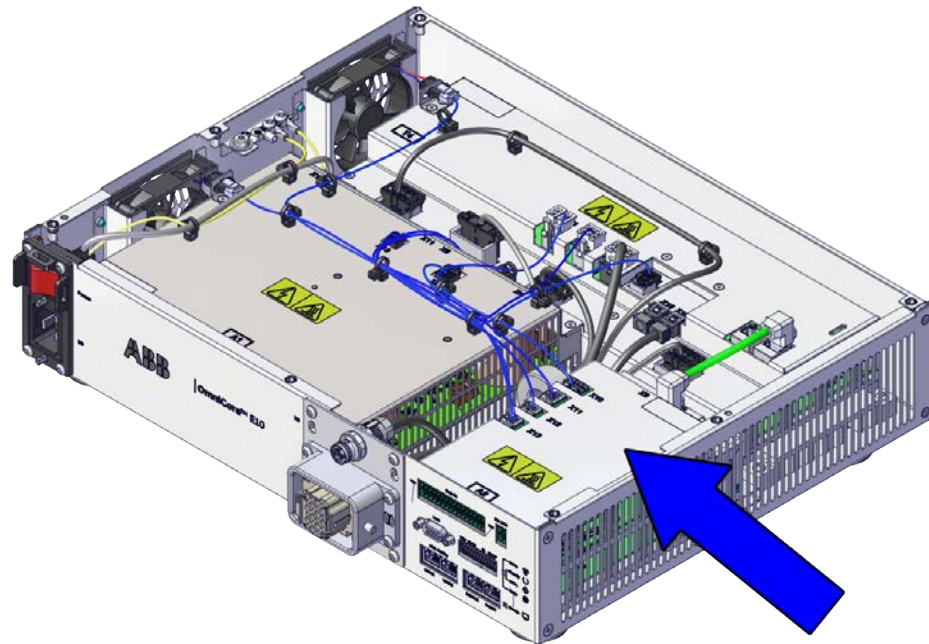

xx2100001325

LEDs

The illustration below shows the LEDs on the computer and logic unit:

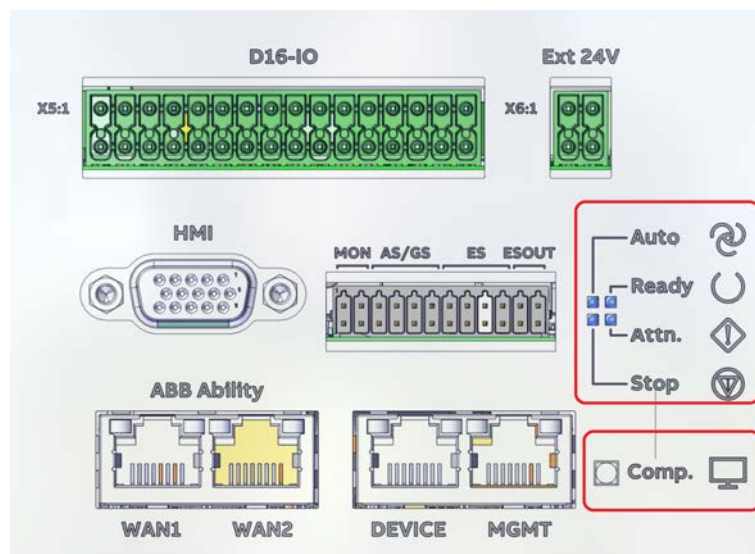

xx2100001559

Continues on next page

Description	Significance
Computer status, Computer (red/green)	<p>The computer status LED indicates the startup progress of RobotWare on the computer and logic unit.</p> <p>Normal behavior:</p> <ol style="list-style-type: none"> 1 Red, solid: Default when turning on the power. 2 Red, flashing (~1Hz): Initial self-test is ongoing and the operating system is loading. 3 Green, even flashing (~1Hz): The operating system is loaded and RobotWare is initializing. 4 Green, uneven flashing (~1Hz): The RobotWare system failed to load or is not installed. 5 Green, solid: The computer is operational and the RobotWare system is fully loaded. <p>If the LED does not turn steady green after approximately 5 minutes then the LED can be used to identify the following issues:</p> <ul style="list-style-type: none"> • No color: The internal power initialization failed. Restart the controller. Replace the computer and logic unit if the problem remains. • Red, solid: Internal error. Restart the controller. Replace the computer and logic unit if the problem remains. • Red, flashing continuously: Failed to load the operating system. Restart the controller. See Controller fails to start on page 189. Replace the computer and logic unit if the problem remains. • Green, even flashing continuously (~1Hz): Failure during start up. Check error messages on FlexPendant. See Controller fails to start on page 189. • Green, uneven flashing: RobotWare Installation Utilities mode.
Auto mode (white)	<p>The Auto mode LED indicates that the robot controller is in automatic mode or not.</p> <ul style="list-style-type: none"> • On: Automatic mode • Off: Non-automatic mode
Attention (white)	<p>The Attention LED indicates that any fault is detected or not.</p> <ul style="list-style-type: none"> • On: Signal SYS_Fault is active. • Off: Signal SYS_Fault is de-active.
Emergency Stop (white)	<p>The Emergency Stop LED indicates that the robot is in E-STOP status or not.</p> <ul style="list-style-type: none"> • On: Robot is in E-STOP status. • Off: Robot is not in E-STOP status.
Ready/Executing (white)	<p>The Ready/Executing LED indicates that the robot is in Motor on status or not.</p> <ul style="list-style-type: none"> • On: Robot is motor on. • Off: Robot is motor off.

This page is intentionally left blank

7 Decommissioning

7.1 Introduction to decommissioning

Introduction

This section contains information to consider when taking a product, robot or controller, out of operation.

It deals with how to handle potentially dangerous components and potentially hazardous materials.



Note

The decommissioning process shall be preceded by a risk assessment.

Disposal of materials used in the robot

All used grease/oils and dead batteries **must** be disposed of in accordance with the current legislation of the country in which the robot and the control unit are installed.

If the robot or the control unit is partially or completely disposed of, the various parts **must** be grouped together according to their nature (which is all iron together and all plastic together), and disposed of accordingly. These parts **must** also be disposed of in accordance with the current legislation of the country in which the robot and control unit are installed.

See also [Environmental information on page 206](#).

Disposal of storage media

Before disposal of any storage equipment (anything from an SD card to a complete controller), make sure that all sensitive information has been deleted.



Tip

To remove all data from the OmniCore controller, use the **Delete user data** function (part of **Delete RobotWare system** function) in RobotWare. See *Operating manual - Integrator's guide OmniCore*.

Transportation

Prepare the robot or parts before transport, this to avoid hazards.

7 Decommissioning

7.2 Environmental information

7.2 Environmental information

Introduction

ABB robots contain components in different materials. During decommissioning, all materials should be dismantled, recycled, or reused responsibly, according to the relevant laws and industrial standards. Robots or parts that can be reused or upcycled helps to reduce the usage of natural resources.

Symbol

The following symbol indicates that the product must not be disposed of as common garbage. Handle each product according to local regulations for the respective content (see table below).

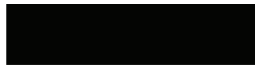

xx1800000058

Materials used in the product

The table specifies some of the materials in the product and their respective use throughout the product.

Dispose components properly according to local regulations to prevent health or environmental hazards.

Material	Example application
Aluminium	Heat sinks on power unit and drive unit
Batteries, Lithium	Computer and logic unit
Brominated flame retardants	Electronics
Copper	Cables
Lead	Electronics
Plastic/rubber	Cables, connectors, etc.
Steel	Cabinet structure, plates, screws, etc.

Continues on next page

China RoHS symbol

The following symbol shows the information to hazardous substances and the environmental protection use period of OmniCore E10 according to "Management Methods for the Restriction of the Use of Hazardous Substances in Electrical and Electronic Products (SJ/T 11364-2014)".



xx190000804

Orange symbol with a number in it: The product contains certain hazardous substances and can be used safely during its environmental protection use period (as indicated by the number in the center) which should enter into the recycling system after its environmental protection use period.

Controller Name	OmniCore E10					
Parts Name	Hazardous substance					
	Lead	Mercury	Cadmium	Hexavalent chromium	Polybrominated biphenyls	Polybrominated diphenyl ethers
Cabinet	○	○	○	○	○	○
Drive unit	○	○	○	○	○	○
Power unit	○	○	○	○	○	○
Computer and logic unit	○	○	○	○	○	○
Small fan	x	○	○	○	○	○
Cable harness	x	○	○	○	○	○
Accessories	○	○	○	○	○	○

This table was developed according to the provisions of SJ/T 11364.

○: The content of such hazardous substance in all homogeneous materials of such component is below the limit required by GB/T 26572.

x: The content of such hazardous substance in a certain homogeneous materials of such component is beyond the limit required by GB/T 26572.

The replacement of the hazardous substances that contained in this product CANNOT be achieved due to restricted by the global technological development level.



Note

This form and environmental protection use period label are based on the regulation in China. These are not necessary to be concerned in other countries.

This page is intentionally left blank

8 Reference information

8.1 Introduction

General

This chapter includes general information, complementing the more specific information in the different procedures in the manual.

8 Reference information

8.2 Applicable standards

8.2 Applicable standards

General

The product is compliant with ISO 10218-1:2011, *Robots for industrial environments - Safety requirements - Part 1 Robots*, and applicable parts in the normative references, as referred to from ISO 10218-1:2011. In case of deviation from ISO 10218-1:2011, these are listed in the declaration of incorporation. The declaration of incorporation is part of the delivery.

Robot standards

Standard	Description
ISO 9283	Manipulating industrial robots – Performance criteria and related test methods
ISO 9787	Robots and robotic devices – Coordinate systems and motion nomenclatures
ISO 9946	Manipulating industrial robots – Presentation of characteristics

Other standards used in design

Standard	Description
IEC 60204-1	Safety of machinery - Electrical equipment of machines - Part 1: General requirements, normative reference from ISO 10218-1
IEC 61000-6-2	Electromagnetic compatibility (EMC) – Part 6-2: Generic standards – Immunity standard for industrial environments
IEC 61000-6-4	Electromagnetic compatibility (EMC) – Part 6-4: Generic standards – Emission standard for industrial environments
ISO 13849-1:2006	Safety of machinery - Safety related parts of control systems - Part 1: General principles for design, normative reference from ISO 10218-1

Region specific standards and regulations

Standard	Description
ANSI/UL 1740	Safety standard for robots and robotic equipment
CAN/CSA Z 434-03	Industrial robots and robot Systems - General safety requirements
EN ISO 10218-1	Robots and robotic devices — Safety requirements for industrial robots — Part 1: Robots

8.3 Unit conversion

Converter table

Use the following table to convert units used in this manual.

Quantity	Units		
Length	1 m	3.28 ft.	39.37 in
Weight	1 kg	2.21 lb.	
Weight	1 g	0.035 ounces	
Pressure	1 bar	100 kPa	14.5 psi
Force	1 N	0.225 lbf	
Moment	1 Nm	0.738 lbf-ft	
Volume	1 L	0.264 US gal	

8 Reference information

8.4 Standard toolkit for controller

8.4 Standard toolkit for controller

General

All service (repair, maintenance and installation) instructions contain lists of tools required to perform the specified activity. All special tools, that is, all tools that are not considered as standard tools as defined below, are listed in their instructions respectively.

This way, the tools required are the sum of the standard toolkit and any tools listed in the instructions.

Standard toolkit for controller

Tool	Description
Screw driver, Torx	Tx10
Screw driver, Torx	Tx20
Screw driver, Torx	Tx25
Ball tipped screw driver, Torx	Tx25
Screw driver, flat blade	4 mm
Screw driver, flat blade	8 mm
Screw driver, flat blade	12 mm
Screw driver	Phillips-1
Box spanner	8 mm

Toolkit recommended for troubleshooting

Tool	Note
Normal shop tools	Contents as specified above.
Multimeter	-
Camera	To document problems or procedures

8.5 Screw joints

General

This section details how to tighten the various types of screw joints on the controller. The instructions and torque values are valid for screw joints comprised of metallic materials and do *not* apply to soft or brittle materials.

Tightening torque

Before tightening any screw, note the following:

- Determine whether a standard tightening torque or special torque is to be applied. The standard torques are specified in the tables below. Any special torques are specified in the Repair, Maintenance or Installation procedure description. Any special torque specified overrides the standard value.
- Use the *correct tightening torque* for each type of screw joint.
- Only use *correctly calibrated* torque keys.
- Always *tighten the joint by hand*, and never use pneumatical tools.
- Use the *correct tightening technique*, i.e. *do not* jerk. Tighten the screw in a slow, flowing motion.
- Maximum allowed total deviation from the specified value is **10%**!

The table below specifies the recommended standard tightening torque for *oil-lubricated screws with slotted or cross-recess heads*.

Dimension	Tightening torque (Nm) Class 4.8, oil-lubricated
M2.5	0.25
M3	0.5
M4	1.2
M5	2.5
M6	5.0

8 Reference information

8.6 Weight specifications

8.6 Weight specifications

Definition

In all repair and maintenance instructions, weights of the components handled are sometimes specified. All components exceeding 22 kg (50 lbs) are high-lighted in this way.

To avoid injury, ABB recommends the use of lifting equipment when handling components with a weight exceeding 22 kg.

Example

Below is an example of how a weight specification is presented:



CAUTION

The transformer weighs 55 kg! All lifting equipment used must be sized accordingly!

8.7 Lifting accessories and lifting instructions

General

Many repair and maintenance activities require different pieces of lifting accessories, which are specified in each procedure.

The use of each piece of lifting accessories is *not* detailed in the activity procedure, but in the instruction delivered with each piece of lifting accessories.

The instructions delivered with the lifting accessories should be stored for later reference.

This page is intentionally left blank

9 Spare parts

Spare part level

ABB spare parts are categorized into two levels, L1 and L2. Always check the part level before conducting a service work on a spare part.

- L1 spare parts

The L1 parts can be replaced in the field. The maintenance and replacement instructions given in the related product manuals must be strictly followed. If there are any problems, contact your local ABB for support.

- L2 spare parts

To replace the L2 parts require specialized training and might need special tools. Only ABB field service personnel or qualified personnel trained by ABB can replace L2 parts.

- L3 spare parts

L3 spare parts shall only be replaced or repaired by qualified ABB service technician with knowledge of the application due to risk of injury to equipment. Improper installation may void warranty.

Continues on next page

9 Spare parts

9.1 Controller parts

9.1 Controller parts



Note

Removed parts and spare parts must not be disassembled or opened.

Continues on next page

9.1.1 Controller system parts

Drive units

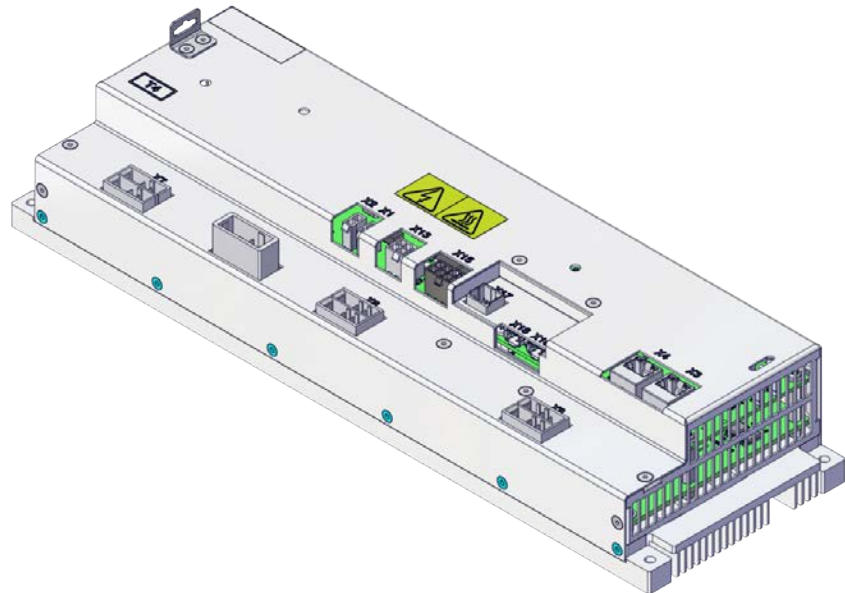

xx2100001316

	Spare part number	Description	Type	Spare part level
-	3HAC074966-001	Drive unit	DSQC3084	L1

Continues on next page

9 Spare parts

9.1.1 Controller system parts

Continued

Power units



xx2100001317

	Spare part number	Description	Type	Spare part level
-	3HAC074985-001	Power unit	DSQC3087	L1

Continues on next page

Harness TPU connection

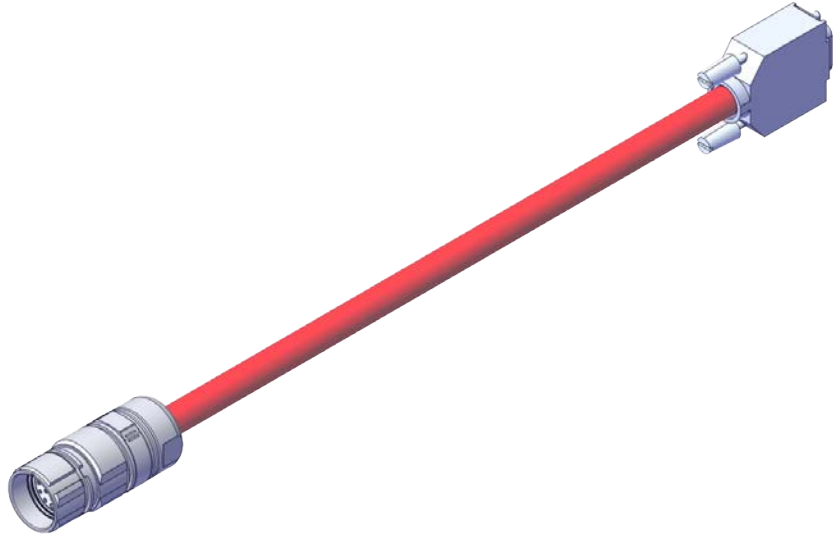

xx2100001319

	Spare part number	Description	Type	Spare part level
-	3HAC077870-001	Harness TPU adapter		L1

9 Spare parts

9.1.2 Mains connection parts

9.1.2 Mains connection parts

Mains power connection

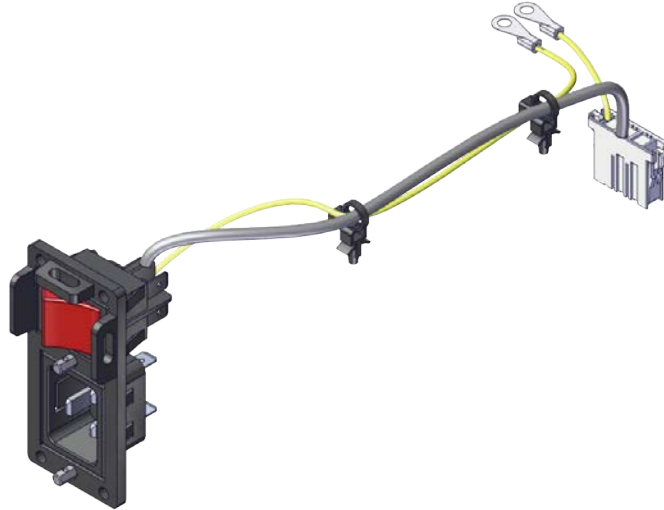

xx2100001322

	Spare part number	Description	Type	Spare part level
-	3HAC075416-001	Harness AC input with SW	Harness-Mains connection	L1
-	3HAC077706-001	Connector AC power inlet	Mating connector for Power inlet	L1

9.1.3 Logic parts

Computer and logic unit



xx210001321

	Spare part number	Description	Type	Spare part level
-	3HAC074970-001	Computer and logic unit		L1

9 Spare parts

9.1.4 Application parts

9.1.4 Application parts

Scalable I/O devices

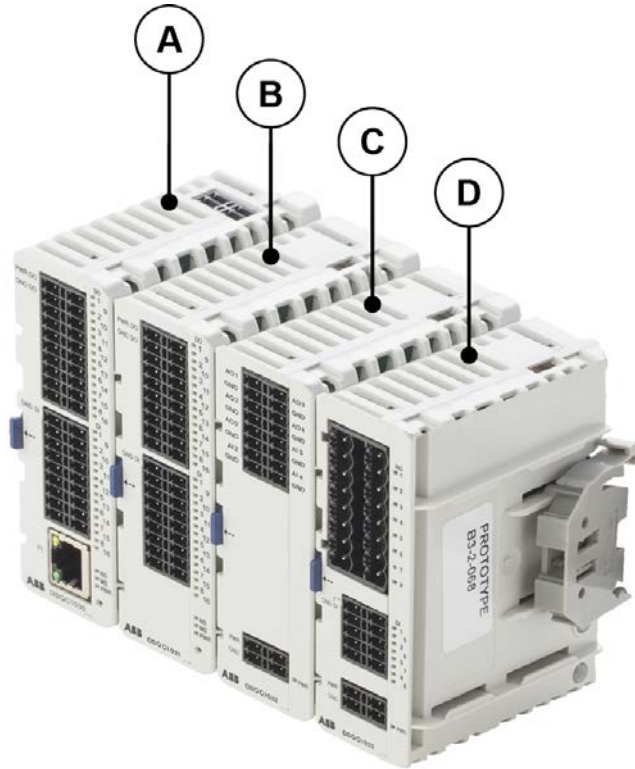

xx1900001939

	Spare part number	Description	Type	Spare part level
A	3HAC058663-001	Scalable I/O Digital base [3032-1] (option)	DSQC1030	L1
-	3HAC060919-001	Connectors digital base/add on		L1
B	3HAC058664-001	Digital add-on [3033-2] (Add-on)	DSQC1031	L1
C	3HAC058665-001	Analog add-on [3034-2] (Add-on)	DSQC1032	L1
-	3HAC060925-001	Connectors I/O Analog (Add-on)		L1
D	3HAC058666-001	Relay add-on [3035-2] (Add-on)	DSQC1033	L1
-	3HAC060926-001	Connectors I/O Relay (Add-on)		L1

9.1.5 Cabinet parts

Fan bracket assembly

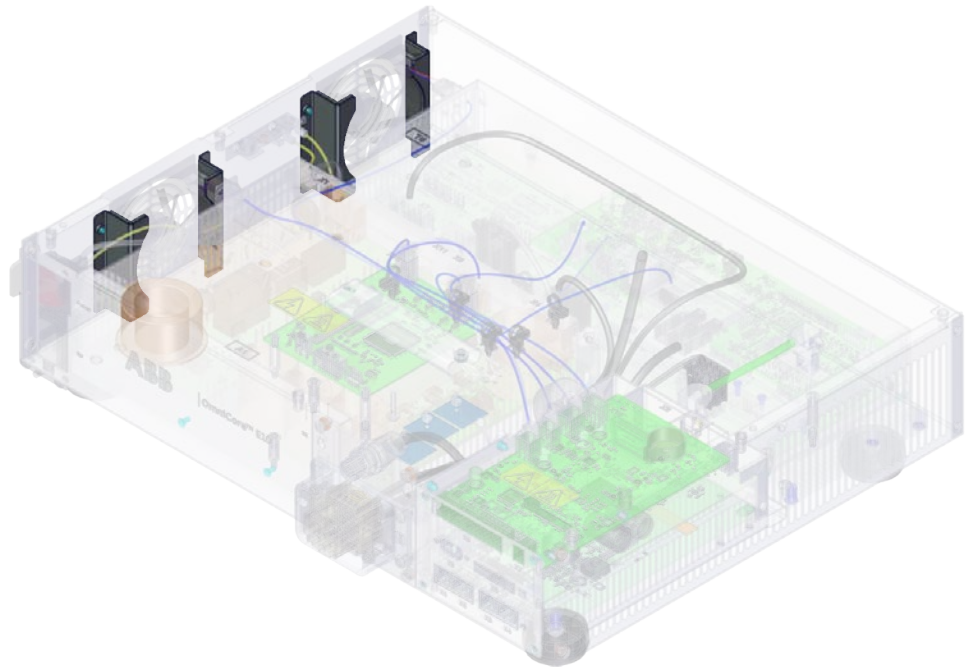

xx2100001312

	Spare part number	Description	Type	Spare part level
-	3HAC078981-001	Fan bracket assembly		L1

Continues on next page

9 Spare parts

9.1.5 Cabinet parts

Continued

Fan pressure bracket assembly



xx2100001313

	Spare part number	Description	Type	Spare part level
-	3HAC078983-001	Fan pressure bracket assembly		L1

Connector computer interface

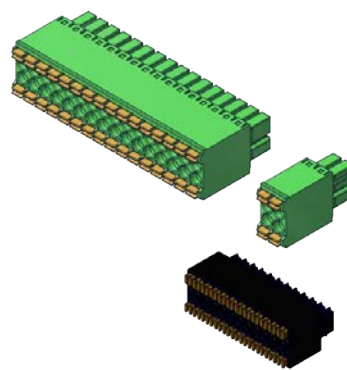

xx2100001315

	Spare part number	Description	Type	Spare part level
-	3HAC076187-001	Connector computer interface		L1

Continues on next page

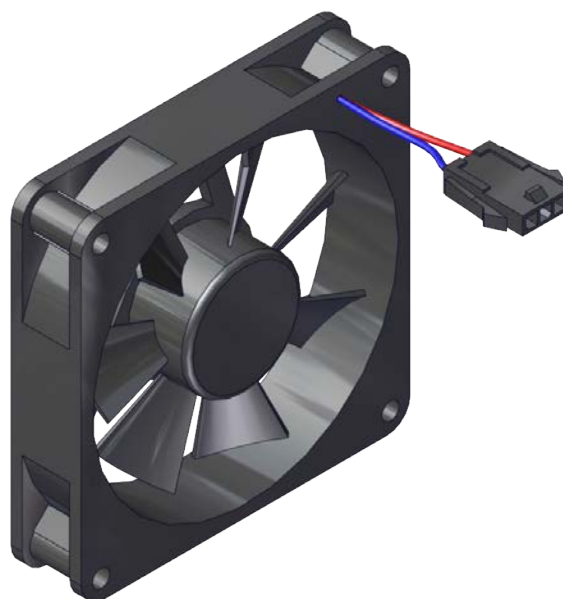
Fans

xx2100001320

	Spare part number	Description	Type	Spare part level
-	3HAC078273-001	Small fan		L1

9 Spare parts

9.1.6 Miscellaneous parts

9.1.6 Miscellaneous parts

Harness assembly SMB and motors power unit

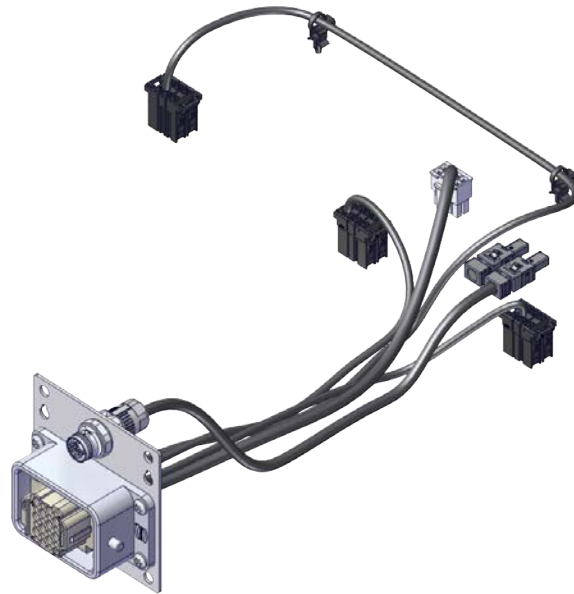

xx2100001318

	Spare part number	Description	Type	Spare part level
-	3HAC075553-001	Harness assembly SMB+Motors power unit		L1

Vision parts

Spare part number	Description	Type	Spare part level
3HAC053944-001	8 mm camera lens, LTC-08F		L1
3HAC053944-002	12.5 mm camera lens, LFC-12.5F		L1
3HAC053944-003	16 mm camera lens, LFC-16F1		L1
3HAC053944-004	25 mm camera lens, LFC-25F1		L1
3HAC087266-001	8 mm camera lens, LMC-ML-M0822UR		L1
3HAC087267-001	12.5 mm camera lens, LMC-ML-M1218UR		L1
3HAC087268-001	16 mm camera lens, LMC-ML-M1616UR		L1
3HAC087269-001	25 mm camera lens, LMC-ML-M2516UR		L1
3HAC053953-001	Integr Vision camera med. Res	DSQC1020	L1
3HAC053954-001	Integr Vision camera high res	DSQC1021	L1

Continues on next page

Spare part number	Description	Type	Spare part level
3HAC087074-001	Integrated vision camera 2MPx	DSQC1098	L1
3HAC087075-001	Integrated vision camera 5MPx	DSQC1099	L1
3HAC051753-003	Integr Vision power cable		L1
3HAC051736-003	Integr Vision ethernet cable		L1
3HAC051753-004	Integr Vision power cable 15 m		L1
3HAC075443-003	Integr Vision ethernet cable 15 m		L1

9 Spare parts

9.1.7 Cables

9.1.7 Cables

Cables

Cables on the drive unit

	Spare part number	Description	Type	Spare part level
-	3HAC075385-001	Harness DC-BUS		L1
-	3HAC075387-001	Harness EtherCAT		L1
-	3HAC075386-001	Harness 24_SYS		L1

Cable on the power unit

	Spare part number	Description	Type	Spare part level
-	3HAC078253-001	Harness Signal cable assembly		L1

9.2 FlexPendant parts

FlexPendant parts

The illustration below shows the placement of the parts in the recommended spare part list.

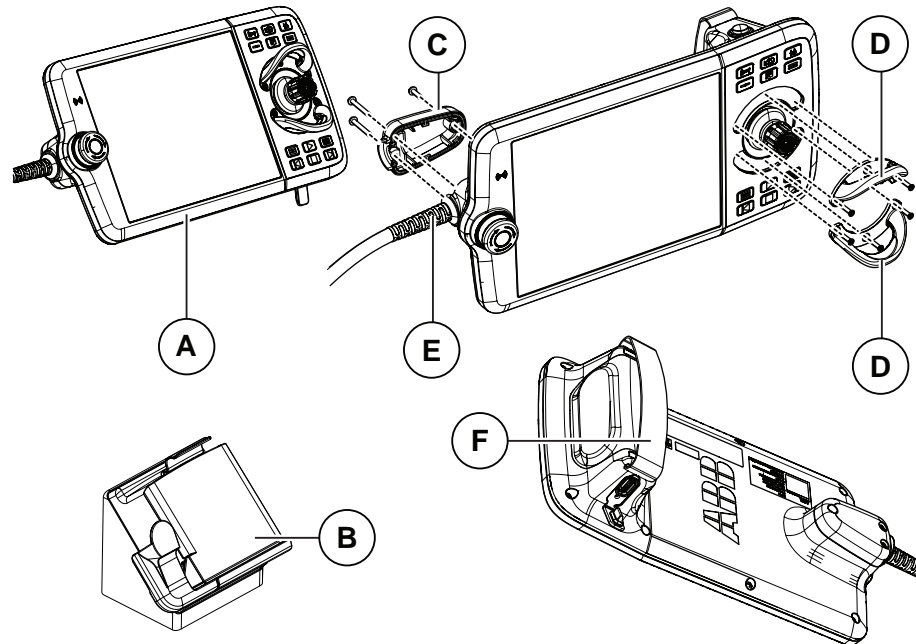

xx180000974

	Spare part number	Description	Type	Spare part level
A	3HAC086996-001	FlexPendant	DSQC3124	L1
B	3HAC064927-001	FlexPendant Holder w/t E-stop cover		L1
C	3HAC065401-001	Power cable cover		L1
D	3HAC065408-001	Joystick guard		L1
E	3HAC064448-002	FlexPendant power cable 3 m		L1
	3HAC064448-001	FlexPendant power cable 10 m		L1
F	3HAC065419-001	Fasten strip		L1

9 Spare parts

9.3.1 Manipulator cables

9.3 Manipulator cables

9.3.1 Manipulator cables

Power cables, IRB 1090, 1100, 1300, 910INV, 920, 930

Power cable length	Article number	Spare part level
Power cable, straight connector, 3 m	3HAC077245-001	L1
Power cable, straight connector, 7 m	3HAC077245-002	L1
Power cable, straight connector, 15 m	3HAC077245-003	L1
Power cable, angled connector, 3 m	3HAC077247-001	L1
Power cable, angled connector, 7 m	3HAC077247-002	L1
Power cable, angled connector, 15 m	3HAC077247-003	L1

Power cables, IRB 1010, 1200

Power cable length	Article number	Spare part level
Power cable 3 m	3HAC061139-001	L1
Power cable 7 m	3HAC061139-002	L1
Power cable 15 m	3HAC061139-003	L1

Signal cables, IRB 1010, 1090, 1100, 1300, 910INV, 920, 930

Signal cable length	Article number	Spare part level
Signal cable, shielded: 3 m	3HAC084767-001	L1
Signal cable, shielded: 7 m	3HAC084767-002	L1
Signal cable, shielded: 15 m	3HAC084767-003	L1

Signal cables, IRB 1200

Signal cable length	Article number	Spare part level
3 m	3HAC080671-001	L1
7 m	3HAC080671-002	L1
15 m	3HAC080671-003	L1

9.3.2 Customer cables - CP/CS connectors (option)**CP/CS cables, IRB 1100, 1300, 910INV, 920, 930**

CP/CS cable length	Article number	Spare part level
3 m	3HAC067449-001	L1
7 m	3HAC067449-002	L1
15 m	3HAC067449-003	L1

CP/CS cables, IRB 1010, 1090

CP/CS cable length	Article number	Spare part level
3 m	3HAC067449-001	L1
7 m	3HAC067449-002	L1

9 Spare parts

9.3.3 Customer cables - Ethernet floor cables

9.3.3 Customer cables - Ethernet floor cables

Ethernet floor cables, IRB 1010, 1100, 1300, 910INV, 920, 930 (option)

One end is RJ45, one end is X-code.

Ethernet floor cable length	Article number	Spare part level
Eth.RJ45_X floor cable, 7 m	3HAC067447-002	L1
Eth.RJ45_X floor cable, 15 m	3HAC067447-003	L1

Ethernet floor cables, IRB 1090 (option)

One end is RJ45, one end is X-code.

Ethernet floor cable length	Article number	Spare part level
Eth.RJ45_X floor cable, 7 m	3HAC067447-002	L1

Index

3

3rd party software, 46

A

allergenic material, 29

aluminum

disposal, 206

ambient temperature

operation, 39

storage, 39

AS

configuring, 98

assembly instructions, 49

assessment of hazards and risks, 29

automatic mode, 28

automatic stop, 98

function test, 120

B

batteries

disposal, 206

brakes not releasing, 181

brominated flame retardants

disposal, 206

C

cabinet lock, 30

cables, 77

carbon dioxide extinguisher, 30

category 0 stop, 22

category 1 stop, 22

cleaning

FlexPendant, 44

cleaning of the controller, 113

cleaning the FlexPendant, 114

climbing on robot, 33

computer and logic unit

replacing, 147

connection

manipulator cables, 77

controller

symbols, 20

controller fails to start, 189

controller mode, 189

cooling fan

replacing, 128

copper

disposal, 206

covers, 126–127

Customer optional power input

connectors, 97

Customer safety interface

connectors, 89

D

damaged bearings, 191

damaged parallel bar, 191

desktop mounting kit, 57

detaching FlexPendant, 81

dimensions, 38

disconnecting FlexPendant, 81

disposal of storage media, 205

drive unit

LED, 197

replacing, 141

E

earth fault protection, 79

emergency stop, 22

function test, 116

emergency stops, 24

enabling device, 25

function test, 118

EN ISO 13849-1, 16

environmental information, 206

ESD

damage elimination, 43

sensitive equipment, 43

esd elimination, 43

external I/O

installing, 108

F

fan

replacing, 128

silencing, 66

fan control functionality, 66

faulty calibration, 191

faulty TCP definition, 191

fire extinguishing, 30

firmware, reflashing failure, 190

FlexPendant

blue screen, 184

cleaning, 44

connecting, disconnecting, 81

storage, 44

FlexPendant holder, 60

FlexPendant joystick not working, 188

FlexPendant not responding, 184

FlexPendant not starting, 184

function tests, 116

G

general stop, 98, 121

GS

configuring, 98

H

hanging

installed hanging, 29

hazard levels, 18

hazardous material, 206

height

installed at a height, 29

hold-to-run, 25

hot surfaces, 33

HRA, 29

I

I/O connectors, 87–88

industrial network, 104

installation activities, 50

installation space, 53

instructions for assembly, 49

integrator responsibility, 29

internal I/O

installing, 108

J

jogging not possible, 188

joystick not working, 188

K

key of the mode switch, 32

L

labels

controller, 20

lead

disposal, 206

LED

computer and logic unit, 202

drive unit, 197

power unit, 199

LEDs , indication, 176

LEDs not lit, 176

licenses, 46

limitation of liability, 15

Lithium

disposal, 206

lock and tag, 30

M

maintenance schedule, 111

manipulator cables, 77

manual full speed mode, 26

manual high speed mode, 26

manual mode, 26

manual reduced speed, 26

mode switch key, 32

motor contactors

function test, 119

MTTF_D, 16

N

national regulations, 29

network security, 45

noise, 191

normal operation mode, 189

O

open source software, OSS, 46

operating conditions, 39

operating mode

automatic mode, 28

function test, 117

manual full speed mode, 26

manual mode, 26

manual reduced speed, 26

original spare parts, 15

P

path accuracy, 191

pedestal

installed on pedestal, 29

performance level, PL, 16

personnel

requirements, 17

PFH_D, 16

PL, performance level, 16

plastic

disposal, 206

power

turn on and off, 68

power failure during start-up, 179

power inlet switch, 68

power unit

LED, 199

replacing, 134

PPE, 17

problem releasing the robot brakes, 181

product standards, 210

protection classes, 40

protection type, 40

protective earth, 80

protective equipment, 17

protective stop

definition, 22

protective wear, 17

R

rack mounting, 55

RCD, 79

recovering from emergency stops, 24

recycling, 206

reduced speed control

function test, 124

reflashing firmware failure, 190

regional regulations, 29

remote I/O

installing, 108

removing

covers, 126

replacements, report, 125

report replacements, 125

required performance level, PLr, 16

residual current device, 79

responsibility and validity, 15

restart controller, 68

risk of burns, 33

robot

protection class, 40

protection types, 40

RobotWare Installation Utilities mode, 189

rubber

disposal, 206

S

safeguarding, 22

safeguard mechanisms

automatic mode, 28

manual mode, 26

safety

ESD, 43

fire extinguishing, 30

signals, 18

signals in manual, 18

stop functions, 22

symbols, 18

symbols on controller, 20

safety devices, 30

safety lock, 68

safety signals

in manual, 18

safety standards, 210

scalable I/O, 105

connectors, 87

installing, 108

scalable I/O external, 105

shipping, 205

signals

safety, 18

silent fan, 66

software licenses, 46

standards, 210

ANSI, 210

- CAN, 210
- start controller, 68
- steel
 - disposal, 206
- stop category 0, 22
- stop category 1, 22
- stops
 - overview, 22
- storage conditions, 39
- symbols
 - safety, 18
- system integrator requirements, 29
- system update failure, 180

T

- teach pendant
 - detach, attach, 81
- temperatures
 - operation, 39
 - storage, 39

- three-position enabling device, 25
 - function test, 118
- tightening torque, 213
- TPU
 - connecting, disconnecting, 81
- transportation, 205
- transportation conditions, 39
- troubleshooting
 - safety, 34

U

- upcycling, 206
- users
 - requirements, 17

V

- validity and responsibility, 15

W

- weight, 39
- wrist strap, 43



ABB AB

Robotics & Discrete Automation

S-721 68 VÄSTERÅS, Sweden

Telephone +46 10-732 50 00

ABB AS

Robotics & Discrete Automation

Nordlysvegen 7, N-4340 BRYNE, Norway

Box 265, N-4349 BRYNE, Norway

Telephone: +47 22 87 2000

ABB Engineering (Shanghai) Ltd.

Robotics & Discrete Automation

No. 4528 Kangxin Highway

PuDong New District

SHANGHAI 201319, China

Telephone: +86 21 6105 6666

ABB Inc.

Robotics & Discrete Automation

1250 Brown Road

Auburn Hills, MI 48326

USA

Telephone: +1 248 391 9000

abb.com/robotics